

Neraca massa dengan  
reaksi kimia

dengan aliran kompleks

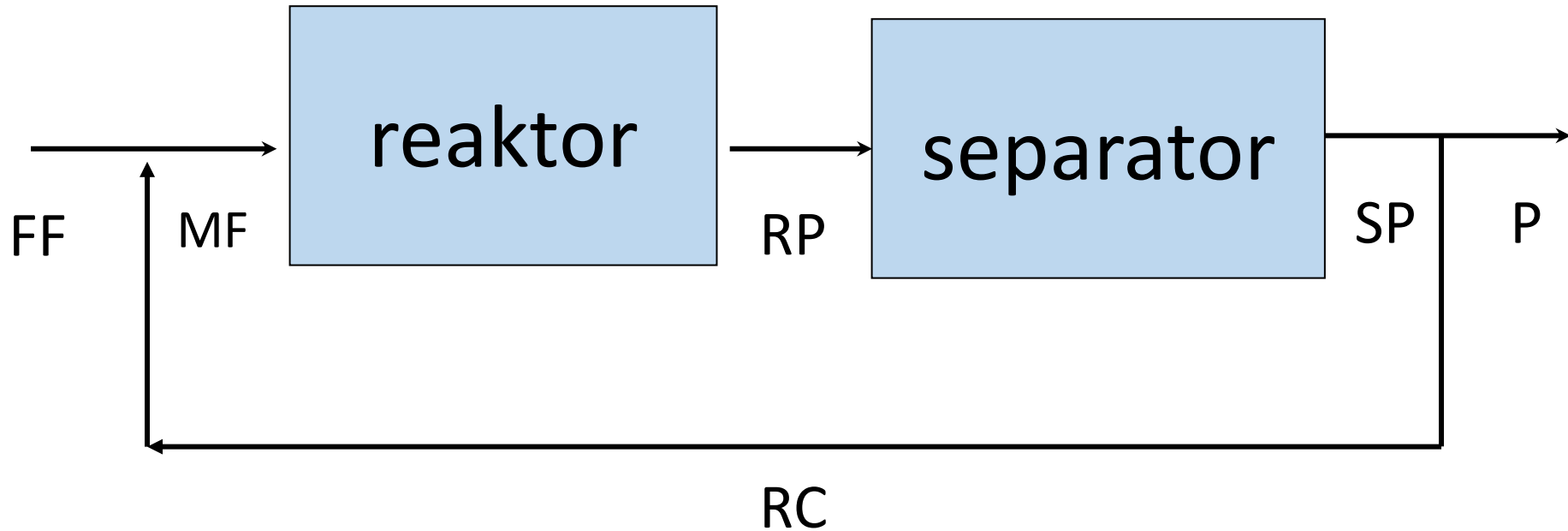



- FF : fresh feed
- MF : mixed feed
- RP : reactor product
- SP : separator product
- RC : recycle
- P : product



# KONVERSI PADA ARUS RECYCLE

- KONVERSI PER PASS

reaktan yg bereaksi / reaktan yang masuk reaktor (MF)

- KONVERSI OVER ALL

reaktan yang bereaksi / reaktan yang diumpankan ke dalam sistem (FF)



# SOAL



- Suatu reaksi antara A dan B diberikan sbb :



Reaksi dilakukan dalam reaktor dengan operasi recycle.

B diumpankan dalam fresh feed (FF) 20% excess. Konversi A per pass 60% dan over all 90%.

Sisa reaktan A yang tak bereaksi dapat dipisahkan secara sempurna dalam separator, dan 25% sisa reaktan B ikut terpisah bersama reaktan A.

Campuran A dan B hasil separator sebagian direcycle dan sebagian dibuang dengan perbandingan RC/W = 5.

Hitung perbandingan mol recycle per mol fresh feed !

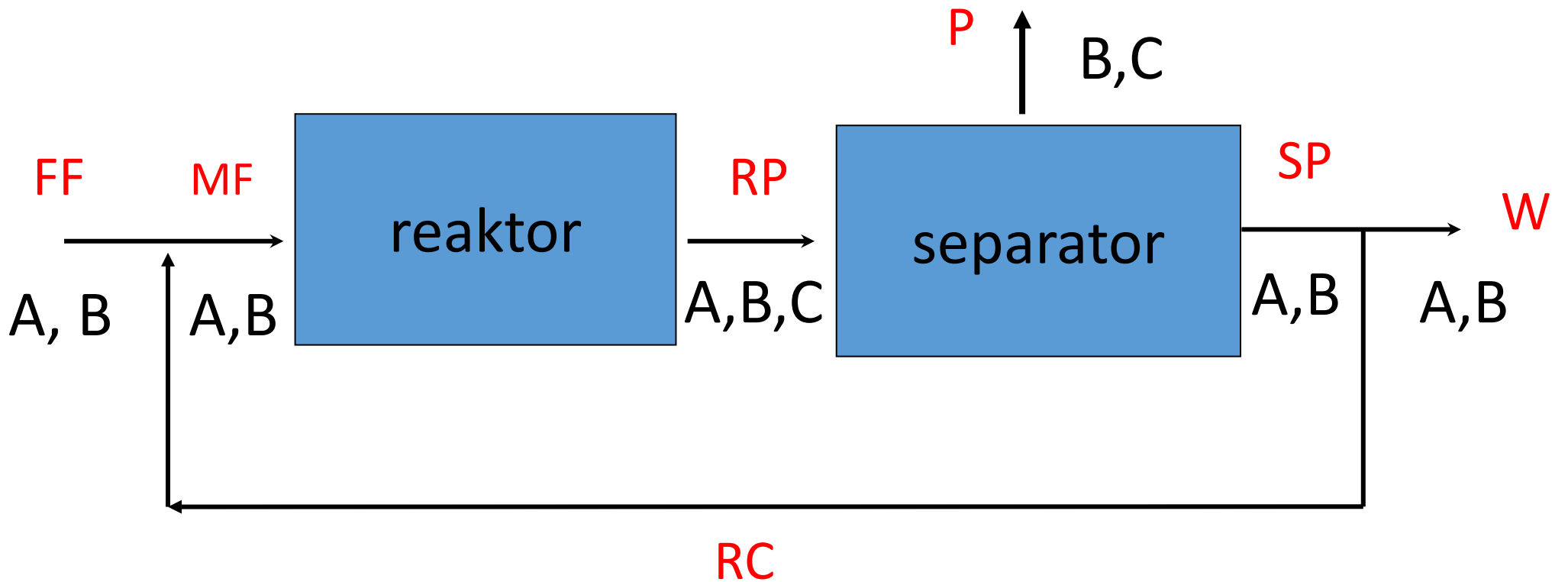

Basis : 100 mol A di FF, atau 100 mol A di MF



# Basis 100 mol A di FF



Komp.	FF	MF	RP	SP	P	RC	W
A	100	?	?	?	0	?	?
B	?	?	?	?	?	?	?
C	?	?	?	?	?	?	?

# PENYELESAIAN



$$A_{FF} = 100 \text{ mol}$$

$$X_{\text{overall}} = 0,9 = A_{\text{berx}} / A_{FF}$$

$$A_{\text{berx}} = 0,9 * 100 = 90 \text{ mol}$$

$$A_{MF} = 90 / 0,6 = 150 \text{ mol}$$

$$A_{RP} = A_{MF} - A_{\text{berx}} = 60 \text{ mol} = A_{SP}$$

$$A_{RC} = A_{MF} - A_{FF} = 50 \text{ mol}$$

$$A_p = 0$$

$$A_W = A_{SP} - A_{RC} = 10 \text{ mol}$$

$$RC / W = 5 / 1$$



Komp.	FF	MF	RP	SP	P	RC	W
A	100	150	60	60	0	50	10
B	?	?	?	?	?	?	?
C	?	?	?	?	?	?	?



# PENYELESAIAN



$$B_{FF} = 1,2 * 3/2 * 100 = 180 \text{ mol}$$

$$B_{MF} = y$$

$$B_{berx} = 3/2 * 90 = 135 \text{ mol}$$

$$B_{RP} = y - 135 \text{ mol}$$

$$B_{SP} = 0,25 * (y - 135) \text{ mol}$$

$$B_{RC} = (5/6) * [0,25 * (y - 135)] \text{ mol}$$

$$B_{W} = (1/6) * [0,25 * (y - 135)] \text{ mol}$$

RC/W = 5/1



# penyelesaian

$$B_{MF} = B_{FF} + B_{RC}$$

$$y = 180 + (5/6) * [0,25 * (y - 135)]$$

$$y = 191,84 \text{ mol} = B_{MF}$$

$$B_{RP} = 56,84 \text{ mol}$$

$$B_{SP} = 14,21 \text{ mol}$$

$$B_p = 42,63 \text{ mol}$$

$$B_{RC} = 11,84 \text{ mol}$$

$$B_W = 2,37 \text{ mol}$$

<b>Komp.</b>	<b>FF</b>	<b>MF</b>	<b>RP</b>	<b>SP</b>	<b>P</b>	<b>RC</b>	<b>W</b>
<b>A</b>	<b>100</b>	<b>150</b>	<b>60</b>	<b>60</b>	<b>0</b>	<b>50</b>	<b>10</b>
<b>B</b>	<b>180</b>	<b>191,84</b>	<b>56,84</b>	<b>14,21</b>	<b>42,63</b>	<b>11,84</b>	<b>2,37</b>
<b>C</b>	<b>0</b>	<b>0</b>	<b>90</b>	<b>0</b>	<b>90</b>	<b>0</b>	<b>0</b>

# Basis 100 mol A di FF

Komp.	FF	MF	RP	SP	P	RC	W
A	100	150	60	60	0	50	10
B	180	191,84	56,84	14,21	42,63	11,84	2,37

$$\begin{aligned}\text{Mol RC / mol FF} &= 61,84 / 280 \\ &= 0,22\end{aligned}$$

BANDINGKAN  
DENGAN BASIS  
100 MOL A DI MF



# SOAL LATIHAN 1

- Dalam operasi pabrik amonia, suatu campuran mol 1:3  $N_2 / H_2$  diumpankan ke dalam unit konverter amonia dengan konversi 25%. Amonia yang terbentuk dipisahkan secara sempurna dengan kondensasi dan gas-gas yang tidak terkonversi menjadi  $NH_3$  direcycle ke reaktor.

Campuran  $N_2$  &  $H_2$  pada fresh feed mengandung 0,2 bagian argon tiap 100 bagian campuran  $N_2$  &  $H_2$ . Batas toleransi argon masuk reaktor adalah 5 bagian tiap 100 bagian campuran  $N_2$  &  $H_2$ .

Hitunglah fraksi dari recycle yang harus dibuang (purge) secara kontinyu !

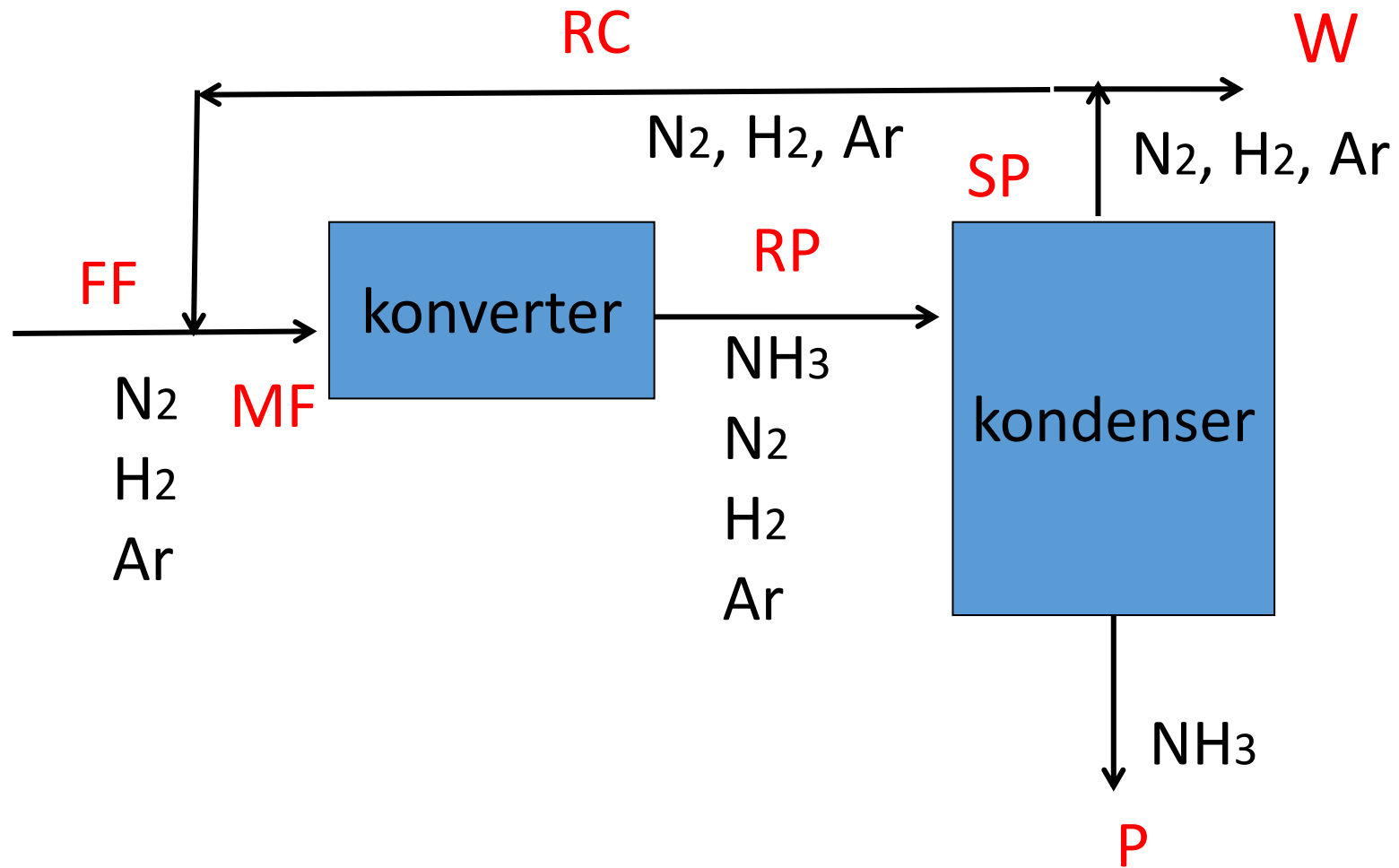

## SOAL LATIHAN 2

- Analisa gas basis kering keluar reaktor etilen oksida sbb :  
C<sub>2</sub>H<sub>4</sub> 3,2%, C<sub>2</sub>H<sub>4</sub>O 0,9%, N<sub>2</sub> 79,6%, CO<sub>2</sub> 5,5%, O<sub>2</sub> 10,8%.

Reaksi yang terjadi :



Hitung : a. Selektivitas

b. Konversi perpass

c. Perbandingan C<sub>2</sub>H<sub>4</sub> dg udara