



**WHAT MAKES US  
HUMAN?**

# Ramu "Ghadya Ka Bacha"

(Balrampur, India, 1954)



Sumber: Wood (2011:7)

**"Cogito ergo sum."**  
(I think, therefor I am.)  
-- Rene Descartes

Can you think without  
using any symbol?

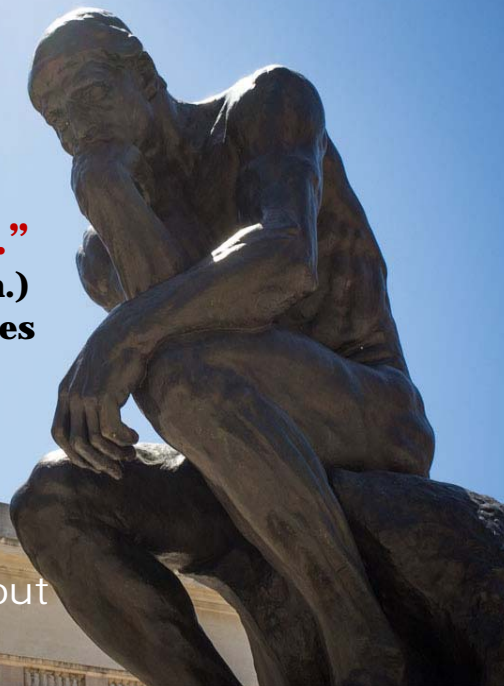

**COMMUNICATION**  
**is a systemic process in which**  
**people interact with and through symbols**  
**to create and interpret meaning**  
(Wood, 2010:12)

## **MODEL LINEAR**

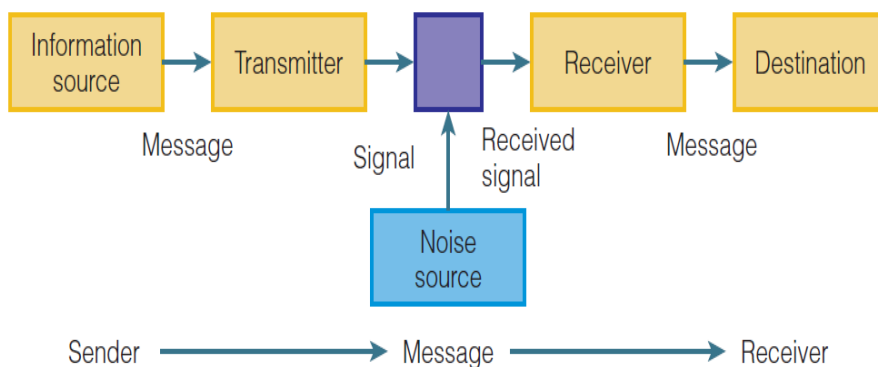

(Sumber: Shanon & Weaver, 1949)

## MODEL INTERAKTIF

---

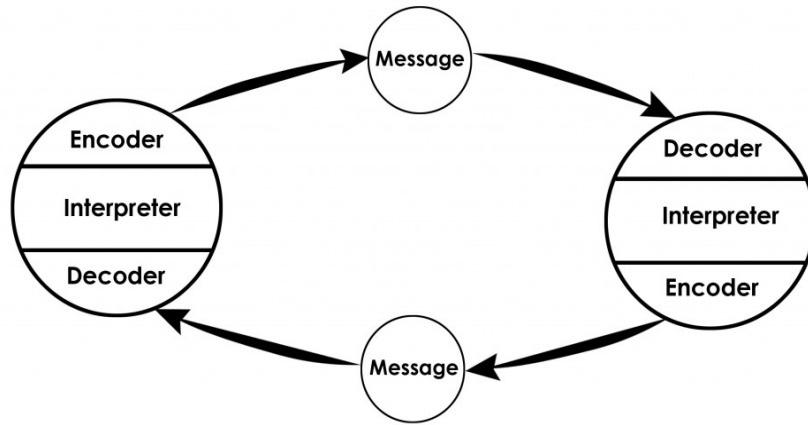

(Sumber: Schramm, 1955)

## MODEL INTERAKTIF

---

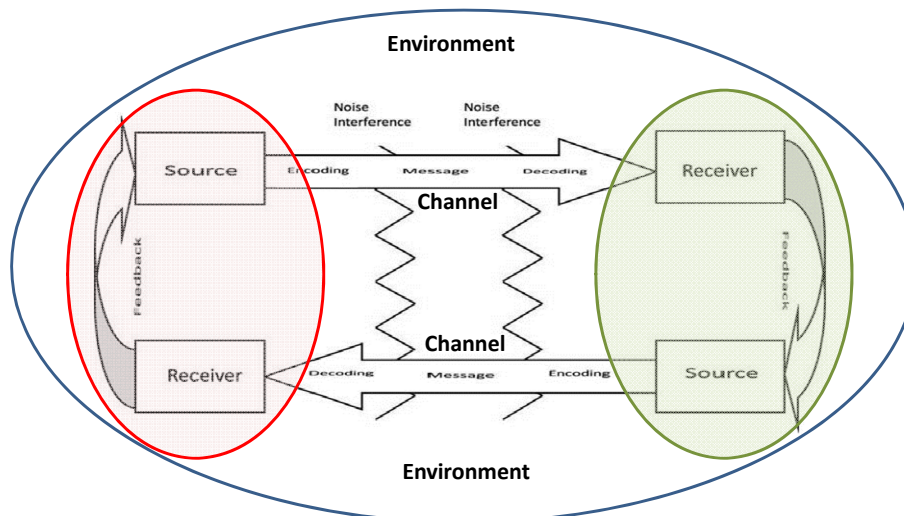

(Visualisasi dari Samovar, Porter dan MacDaniel, 2012)

# MODEL TRANSAKSIONAL

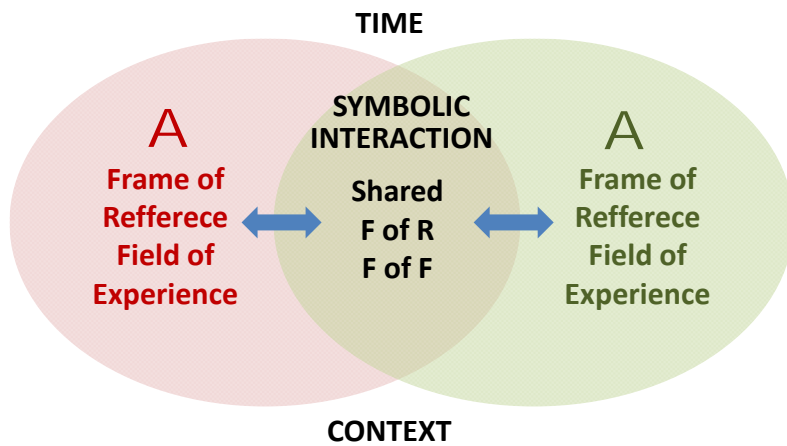

(Adaptasi dari Wood, 1997)

# LEVEL KOMUNIKASI

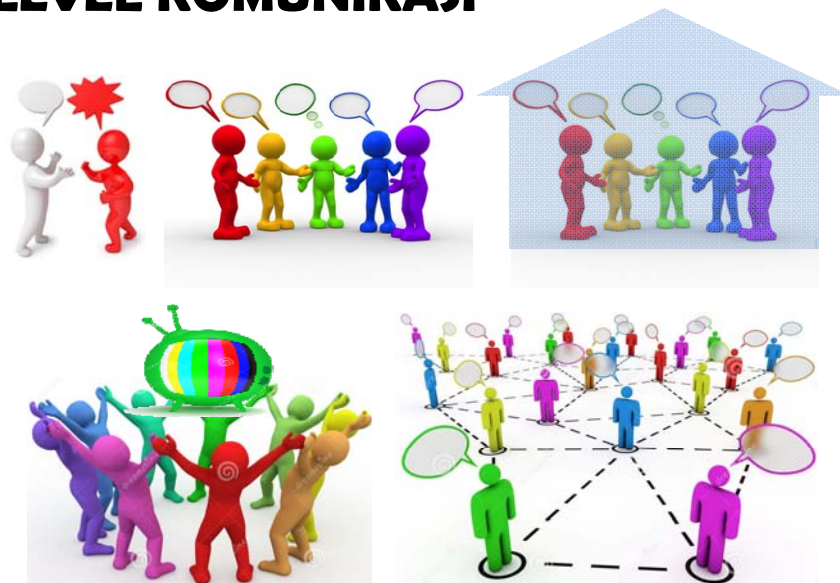

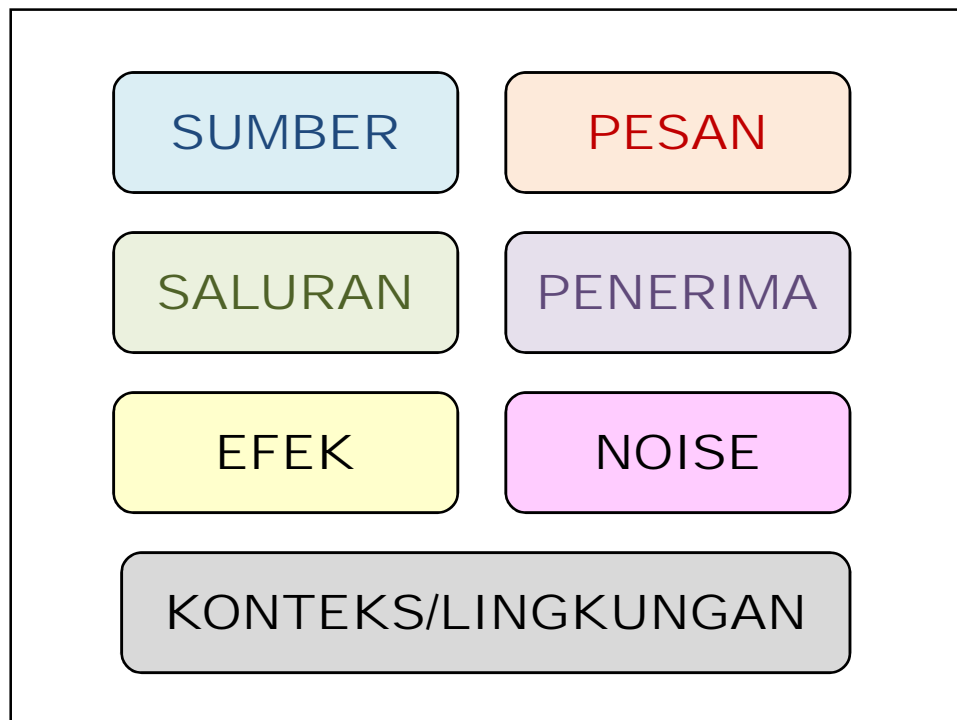

## Daftar Pustaka

---

- Bates, Daniel G. dan Plog, Fred. *Human Adaptive Strategies*. New York: Mcgraw-Hill, 1990.
- Samovar, Larry A.; Porter, Richard E.; McDaniel, Edwin R. McDaniel. *Intercultural Communication: a Reader 13<sup>th</sup> Ed*. Boston: Wadsworth, 2012.
- Schramm, W. (1955). *The process and effects of mass communication*. Urbana: University of Illinois Press, 1955.
- Wood, Julia T. *Communication Mosaics: an Introduction to the Field of Communication 6<sup>th</sup> Ed*. Boston: Wadsworth, 2011.
- Wood, Julia T. Diversity in dialogue: Communication between friends. In J. Makau and R. Arnett (Eds.), *Ethics of Communication in an Age of Diversity* (pp. 5–26). Urbana: University of Illinois Press, 1997