

5

APPLYING NEWTON'S LAWS

LEARNING GOALS

By studying this chapter, you will learn:

- How to use Newton's first law to solve problems involving the forces that act on a body in equilibrium.
- How to use Newton's second law to solve problems involving the forces that act on an accelerating body.
- The nature of the different types of friction forces—static friction, kinetic friction, rolling friction, and fluid resistance—and how to solve problems that involve these forces.
- How to solve problems involving the forces that act on a body moving along a circular path.
- The key properties of the four fundamental forces of nature.



? This skydiver is descending under a parachute at a steady rate. In this situation, which has a greater magnitude: the force of gravity or the upward force of the air on the skydiver?

We saw in Chapter 4 that Newton's three laws of motion, the foundation of classical mechanics, can be stated very simply. But *applying* these laws to situations such as an iceboat skating across a frozen lake, a toboggan sliding down a hill, or an airplane making a steep turn requires analytical skills and problem-solving technique. In this chapter we'll help you extend the problem-solving skills you began to develop in Chapter 4.

We'll begin with equilibrium problems, in which we analyze the forces that act on a body at rest or moving with constant velocity. We'll then consider bodies that are not in equilibrium, for which we'll have to deal with the relationship between forces and motion. We'll learn how to describe and analyze the contact force that acts on a body when it rests on or slides over a surface. We'll also analyze the forces that act on a body that moves in a circle with constant speed. We close the chapter with a brief look at the fundamental nature of force and the classes of forces found in our physical universe.

5.1 Using Newton's First Law: Particles in Equilibrium

We learned in Chapter 4 that a body is in *equilibrium* when it is at rest or moving with constant velocity in an inertial frame of reference. A hanging lamp, a kitchen table, an airplane flying straight and level at a constant speed—all are examples of equilibrium situations. In this section we consider only equilibrium of a body that can be modeled as a particle. (In Chapter 11 we'll see how to analyze a body in equilibrium that can't be represented adequately as a particle, such as a bridge that's supported at various points along its span.) The essential

physical principle is Newton's first law: When a particle is in equilibrium, the *net* force acting on it—that is, the vector sum of all the forces acting on it—must be zero:

$$\sum \vec{F} = \mathbf{0} \quad (\text{particle in equilibrium, vector form}) \quad (5.1)$$

We most often use this equation in component form:

$$\sum F_x = 0 \quad \sum F_y = 0 \quad (\text{particle in equilibrium, component form}) \quad (5.2)$$

This section is about using Newton's first law to solve problems dealing with bodies in equilibrium. Some of these problems may seem complicated, but the important thing to remember is that *all* problems involving particles in equilibrium are done in the same way. Problem-Solving Strategy 5.1 details the steps you need to follow for any and all such problems. Study this strategy carefully, look at how it's applied in the worked-out examples, and try to apply it yourself when you solve assigned problems.

Problem-Solving Strategy 5.1 Newton's First Law: Equilibrium of a Particle



IDENTIFY *the relevant concepts:* You must use Newton's *first* law for any problem that involves forces acting on a body in equilibrium—that is, either at rest or moving with constant velocity. For example, a car is in equilibrium when it's parked, but also when it's traveling down a straight road at a steady speed.

If the problem involves more than one body and the bodies interact with each other, you'll also need to use Newton's *third* law. This law allows you to relate the force that one body exerts on a second body to the force that the second body exerts on the first one.

Identify the target variable(s). Common target variables in equilibrium problems include the magnitude and direction (angle) of one of the forces, or the components of a force.

SET UP *the problem* using the following steps:

1. Draw a very simple sketch of the physical situation, showing dimensions and angles. You don't have to be an artist!
2. Draw a free-body diagram for each body that is in equilibrium. For the present, we consider the body as a particle, so you can represent it as a large dot. In your free-body diagram, *do not* include the other bodies that interact with it, such as a surface it may be resting on or a rope pulling on it.
3. Ask yourself what is interacting with the body by touching it or in any other way. On your free-body diagram, draw a force vector for each interaction. Label each force with a symbol for the *magnitude* of the force. If you know the angle at which a force is directed, draw the angle accurately and label it. Include the body's weight, unless the body has negligible mass. If the mass is given, use $w = mg$ to find the weight. A surface in contact with the body exerts a normal force perpendicular to the surface and possibly a friction force parallel to the surface. A rope or chain exerts a pull (never a push) in a direction along its length.
4. *Do not* show in the free-body diagram any forces exerted by the body on any other body. The sums in Eqs. (5.1) and (5.2)

include only forces that act *on* the body. For each force on the body, ask yourself "What other body causes that force?" If you can't answer that question, you may be imagining a force that isn't there.

5. Choose a set of coordinate axes and include them in your free-body diagram. (If there is more than one body in the problem, choose axes for each body separately.) Label the positive direction for each axis. If a body rests or slides on a plane surface, it usually simplifies things to choose axes that are parallel and perpendicular to this surface, even when the plane is tilted.

EXECUTE *the solution* as follows:

1. Find the components of each force along each of the body's coordinate axes. Draw a wiggly line through each force vector that has been replaced by its components, so you don't count it twice. The *magnitude* of a force is always positive, but its *components* may be positive or negative.
2. Set the sum of all *x*-components of force equal to zero. In a separate equation, set the sum of all *y*-components equal to zero. (*Never* add *x*- and *y*-components in a single equation.)
3. If there are two or more bodies, repeat all of the above steps for each body. If the bodies interact with each other, use Newton's third law to relate the forces they exert on each other.
4. Make sure that you have as many independent equations as the number of unknown quantities. Then solve these equations to obtain the target variables.

EVALUATE *your answer:* Look at your results and ask whether they make sense. When the result is a symbolic expression or formula, check to see that your formula works for any special cases (particular values or extreme cases for the various quantities) for which you can guess what the results ought to be.

Example 5.1 One-dimensional equilibrium: Tension in a massless rope

A gymnast with mass $m_G = 50.0$ kg suspends herself from the lower end of a hanging rope of negligible mass. The upper end of the rope is attached to the gymnasium ceiling. (a) What is the gymnast's weight? (b) What force (magnitude and direction) does the rope exert on her? (c) What is the tension at the top of the rope?

SOLUTION

IDENTIFY and SET UP: The gymnast and the rope are in equilibrium, so we can apply Newton's first law to both bodies. We'll use Newton's third law to relate the forces that they exert on each other. The target variables are the gymnast's weight, w_G ; the force that the bottom of the rope exerts on the gymnast (call it $T_{R \text{ on } G}$); and the force that the ceiling exerts on the top of the rope (call it $T_{C \text{ on } R}$). Figure 5.1 shows our sketch of the situation and free-body diagrams for the gymnast and for the rope. We take the positive y -axis to be upward in each diagram. Each force acts in the vertical direction and so has only a y -component.

The forces $T_{R \text{ on } G}$ (the upward force of the rope on the gymnast, Fig. 5.1b) and $T_{G \text{ on } R}$ (the downward force of the gymnast on the rope, Fig. 5.1c) form an action–reaction pair. By Newton's third law, they must have the same magnitude.

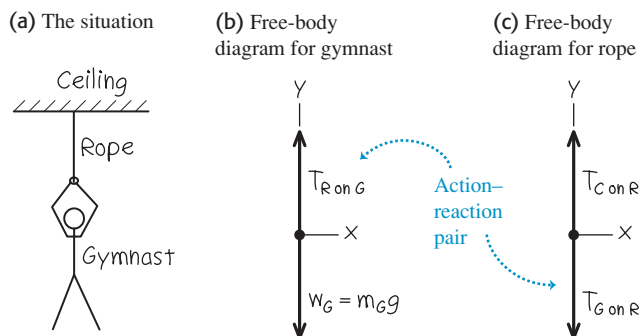
5.1 Our sketches for this problem.

Note that Fig. 5.1c includes only the forces that act *on* the rope. In particular, it doesn't include the force that the *rope* exerts on the *ceiling* (compare the discussion of the apple in Conceptual Example 4.9 in Section 4.5). Similarly, the force that the rope exerts on the ceiling doesn't appear in Fig. 5.1c.

EXECUTE: (a) The magnitude of the gymnast's weight is the product of her mass and the acceleration due to gravity, g :

$$w_G = m_G g = (50.0 \text{ kg})(9.80 \text{ m/s}^2) = 490 \text{ N}$$

(b) The gravitational force on the gymnast (her weight) points in the negative y -direction, so its y -component is $-w_G$. The upward force of the rope on the gymnast has unknown magnitude $T_{R \text{ on } G}$ and positive y -component $+T_{R \text{ on } G}$. We find this using Newton's first law:

$$\begin{aligned} \text{Gymnast: } \sum F_y &= T_{R \text{ on } G} + (-w_G) = 0 \quad \text{so} \\ T_{R \text{ on } G} &= w_G = 490 \text{ N} \end{aligned}$$

The rope pulls *up* on the gymnast with a force $T_{R \text{ on } G}$ of magnitude 490 N. (By Newton's third law, the gymnast pulls *down* on the rope with a force of the same magnitude, $T_{G \text{ on } R} = 490$ N.)

(c) We have assumed that the rope is weightless, so the only forces on it are those exerted by the ceiling (upward force of unknown magnitude $T_{C \text{ on } R}$) and by the gymnast (downward force of magnitude $T_{G \text{ on } R} = 490$ N). From Newton's first law, the *net* vertical force on the rope in equilibrium must be zero:

$$\begin{aligned} \text{Rope: } \sum F_y &= T_{C \text{ on } R} + (-T_{G \text{ on } R}) = 0 \quad \text{so} \\ T_{C \text{ on } R} &= T_{G \text{ on } R} = 490 \text{ N} \end{aligned}$$

EVALUATE: The *tension* at any point in the rope is the magnitude of the force that acts at that point. For this weightless rope, the tension $T_{G \text{ on } R}$ at the lower end has the same value as the tension $T_{C \text{ on } R}$ at the upper end. For such an ideal weightless rope, the tension has the same value at any point along the rope's length. (See the discussion in Conceptual Example 4.10 in Section 4.5.)

Example 5.2 One-dimensional equilibrium: Tension in a rope with mass

Find the tension at each end of the rope in Example 5.1 if the weight of the rope is 120 N.

SOLUTION

IDENTIFY and SET UP: As in Example 5.1, the target variables are the magnitudes $T_{G \text{ on } R}$ and $T_{C \text{ on } R}$ of the forces that act at the bottom and top of the rope, respectively. Once again, we'll apply Newton's first law to the gymnast and to the rope, and use Newton's third law to relate the forces that the gymnast and rope exert on each other. Again we draw separate free-body diagrams for the gymnast (Fig. 5.2a) and the rope (Fig. 5.2b). There is now a *third* force acting on the rope, however: the weight of the rope, of magnitude $w_R = 120$ N.

EXECUTE: The gymnast's free-body diagram is the same as in Example 5.1, so her equilibrium condition is also the same. From

Newton's third law, $T_{R \text{ on } G} = T_{G \text{ on } R}$, and we again have

$$\begin{aligned} \text{Gymnast: } \sum F_y &= T_{R \text{ on } G} + (-w_G) = 0 \quad \text{so} \\ T_{R \text{ on } G} &= T_{G \text{ on } R} = w_G = 490 \text{ N} \end{aligned}$$

The equilibrium condition $\sum F_y = 0$ for the rope is now

$$\text{Rope: } \sum F_y = T_{C \text{ on } R} + (-T_{G \text{ on } R}) + (-w_R) = 0$$

Note that the y -component of $T_{C \text{ on } R}$ is positive because it points in the $+y$ -direction, but the y -components of both $T_{G \text{ on } R}$ and w_R are negative. We solve for $T_{C \text{ on } R}$ and substitute the values $T_{G \text{ on } R} = T_{R \text{ on } G} = 490$ N and $w_R = 120$ N:

$$T_{C \text{ on } R} = T_{G \text{ on } R} + w_R = 490 \text{ N} + 120 \text{ N} = 610 \text{ N}$$

EVALUATE: When we include the weight of the rope, the tension is *different* at the rope's two ends: 610 N at the top and 490 N at

the bottom. The force $T_{C \text{ on } R} = 610 \text{ N}$ exerted by the ceiling has to hold up both the 490-N weight of the gymnast and the 120-N weight of the rope.

To see this more clearly, we draw a free-body diagram for a composite body consisting of the gymnast and rope together (Fig. 5.2c). Only two external forces act on this composite body: the force $T_{C \text{ on } R}$ exerted by the ceiling and the total weight $w_G + w_R = 490 \text{ N} + 120 \text{ N} = 610 \text{ N}$. (The forces $T_{G \text{ on } R}$ and $T_{R \text{ on } G}$ are *internal* to the composite body. Newton's first law applies only to *external* forces, so these internal forces play no role.) Hence Newton's first law applied to this composite body is

$$\text{Composite body: } \sum F_y = T_{C \text{ on } R} + [-(w_G + w_R)] = 0$$

and so $T_{C \text{ on } R} = w_G + w_R = 610 \text{ N}$.

Treating the gymnast and rope as a composite body is simpler, but we can't find the tension $T_{G \text{ on } R}$ at the bottom of the rope by this method. *Moral: Whenever you have more than one body in a problem involving Newton's laws, the safest approach is to treat each body separately.*

5.2 Our sketches for this problem, including the weight of the rope.

(a) Free-body diagram for gymnast (b) Free-body diagram for rope (c) Free-body diagram for gymnast and rope as a composite body

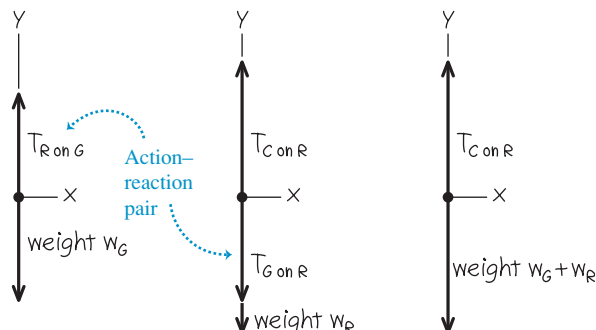

Example 5.3 Two-dimensional equilibrium

In Fig. 5.3a, a car engine with weight w hangs from a chain that is linked at ring O to two other chains, one fastened to the ceiling and the other to the wall. Find expressions for the tension in each of the three chains in terms of w . The weights of the ring and chains are negligible compared with the weight of the engine.

SOLUTION

IDENTIFY and SET UP: The target variables are the tension magnitudes T_1 , T_2 , and T_3 in the three chains (Fig. 5.3a). All the bodies are in equilibrium, so we'll use Newton's first law. We need three independent equations, one for each target variable. However, applying Newton's first law to just one body gives us only *two* equations, as in Eqs. (5.2). So we'll have to consider more than one body in equilibrium. We'll look at the engine (which is acted on by T_1) and the ring (which is acted on by all three chains and so is acted on by all three tensions).

Figures 5.3b and 5.3c show our free-body diagrams and choice of coordinate axes. There are two forces that act on the engine: its weight w and the upward force T_1 exerted by the vertical chain.

Three forces act on the ring: the tensions from the vertical chain (T_1), the horizontal chain (T_2), and the slanted chain (T_3). Because the vertical chain has negligible weight, it exerts forces of the same magnitude T_1 at both of its ends (see Example 5.1). (If the weight of this chain were not negligible, these two forces would have different magnitudes like the rope in Example 5.2.) The weight of the ring is also negligible, which is why it isn't included in Fig. 5.3c.

EXECUTE: The forces acting on the engine are along the y -axis only, so Newton's first law says

$$\text{Engine: } \sum F_y = T_1 + (-w) = 0 \quad \text{and} \quad T_1 = w$$

The horizontal and slanted chains don't exert forces on the engine itself because they are not attached to it. These forces do appear when we apply Newton's first law to the ring, however. In the free-body diagram for the ring (Fig. 5.3c), remember that T_1 , T_2 , and T_3 are the *magnitudes* of the forces. We resolve the force with magnitude T_3 into its x - and y -components. The ring is in equilibrium, so using Newton's first law we can write (separate)

5.3 (a) The situation. (b), (c) Our free-body diagrams.

(a) Engine, chains, and ring

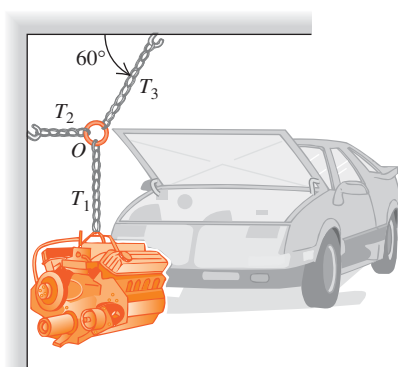

(b) Free-body diagram for engine



(c) Free-body diagram for ring O

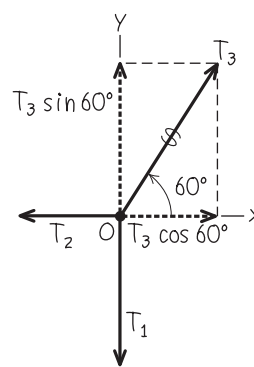

Continued

equations stating that the x - and y -components of the net force on the ring are zero:

$$\begin{aligned}\text{Ring: } \sum F_x &= T_3 \cos 60^\circ + (-T_2) = 0 \\ \text{Ring: } \sum F_y &= T_3 \sin 60^\circ + (-T_1) = 0\end{aligned}$$

Because $T_1 = w$ (from the engine equation), we can rewrite the second ring equation as

$$T_3 = \frac{T_1}{\sin 60^\circ} = \frac{w}{\sin 60^\circ} = 1.2w$$

We can now use this result in the first ring equation:

$$T_2 = T_3 \cos 60^\circ = w \frac{\cos 60^\circ}{\sin 60^\circ} = 0.58w$$

Example 5.4 An inclined plane

A car of weight w rests on a slanted ramp attached to a trailer (Fig. 5.4a). Only a cable running from the trailer to the car prevents the car from rolling off the ramp. (The car's brakes are off and its transmission is in neutral.) Find the tension in the cable and the force that the ramp exerts on the car's tires.

SOLUTION

IDENTIFY: The car is in equilibrium, so we use Newton's first law. The ramp exerts a separate force on each of the car's tires, but for simplicity we lump these forces into a single force. For a further simplification, we'll neglect any friction force the ramp exerts on the tires (see Fig. 4.2b). Hence the ramp only exerts a force on the car that is *perpendicular* to the ramp. As in Section 4.1, we call this force the *normal* force (see Fig. 4.2a). The two target variables are the magnitude n of the normal force and the magnitude T of the tension in the cable.

SET UP: Figure 5.4 shows the situation and a free-body diagram for the car. The three forces acting on the car are its weight (magnitude w), the tension in the cable (magnitude T), and the normal force (magnitude n). Note that the angle α between the ramp and the horizontal is equal to the angle α between the weight vector \vec{w} and the downward normal to the plane of the ramp. Note also that we choose the x - and y -axes to be parallel and perpendicular to the ramp so that we only need to resolve one force (the weight) into x - and y -components. If we chose axes that were horizontal and vertical, we'd have to resolve both the normal force and the tension into components.

5.4 A cable holds a car at rest on a ramp.

(a) Car on ramp

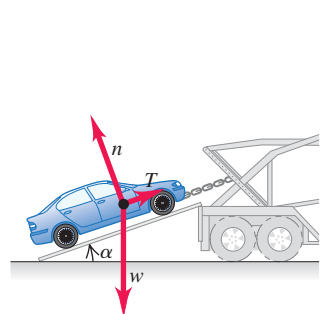

(b) Free-body diagram for car

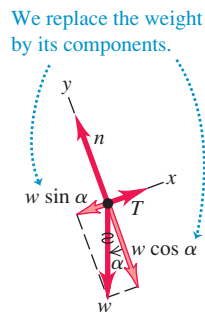

EVALUATE: The chain attached to the ceiling exerts a force on the ring with a *vertical* component equal to T_1 , which in turn is equal to w . But this force also has a horizontal component, so its magnitude T_3 is somewhat larger than w . This chain is under the greatest tension and is the one most susceptible to breaking.

To get enough equations to solve this problem, we had to consider not only the forces on the engine but also the forces acting on a second body (the ring connecting the chains). Situations like this are fairly common in equilibrium problems, so keep this technique in mind.

EXECUTE: To write down the x - and y -components of Newton's first law, we must first find the components of the weight. One complication is that the angle α in Fig. 5.4b is *not* measured from the $+x$ -axis toward the $+y$ -axis. Hence we *cannot* use Eqs. (1.6) directly to find the components. (You may want to review Section 1.8 to make sure that you understand this important point.)

One way to find the components of \vec{w} is to consider the right triangles in Fig. 5.4b. The sine of α is the magnitude of the x -component of \vec{w} (that is, the side of the triangle opposite α) divided by the magnitude w (the hypotenuse of the triangle). Similarly, the cosine of α is the magnitude of the y -component (the side of the triangle adjacent to α) divided by w . Both components are negative, so $w_x = -w \sin \alpha$ and $w_y = -w \cos \alpha$.

Another approach is to recognize that one component of \vec{w} must involve $\sin \alpha$ while the other component involves $\cos \alpha$. To decide which is which, draw the free-body diagram so that the angle α is noticeably smaller or larger than 45° . (You'll have to fight the natural tendency to draw such angles as being close to 45° .) We've drawn Fig. 5.4b so that α is smaller than 45° , so $\sin \alpha$ is less than $\cos \alpha$. The figure shows that the x -component of \vec{w} is smaller than the y -component, so the x -component must involve $\sin \alpha$ and the y -component must involve $\cos \alpha$. We again find $w_x = -w \sin \alpha$ and $w_y = -w \cos \alpha$.

In Fig. 5.4b we draw a wiggly line through the original vector representing the weight to remind us not to count it twice. Newton's first law gives us

$$\begin{aligned}\sum F_x &= T + (-w \sin \alpha) = 0 \\ \sum F_y &= n + (-w \cos \alpha) = 0\end{aligned}$$

(Remember that T , w , and n are all *magnitudes* of vectors and are therefore all positive.) Solving these equations for T and n , we find

$$\begin{aligned}T &= w \sin \alpha \\ n &= w \cos \alpha\end{aligned}$$

EVALUATE: Our answers for T and n depend on the value of α . To check this dependence, let's look at some special cases. If the ramp is horizontal ($\alpha = 0$), we get $T = 0$ and $n = w$. As you might expect, no cable tension T is needed to hold the car, and the normal force n is equal in magnitude to the weight. If the ramp is vertical ($\alpha = 90^\circ$), we get $T = w$ and $n = 0$. The cable tension T supports

all of the car's weight, and there's nothing pushing the car against the ramp.

CAUTION Normal force and weight may not be equal It's a common error to automatically assume that the magnitude n of the normal force is equal to the weight w : Our result shows that this is *not* true in general. It's always best to treat n as a variable and solve for its value, as we have done here. **I**

Example 5.5 Equilibrium of bodies connected by cable and pulley

Blocks of granite are to be hauled up a 15° slope out of a quarry, and dirt is to be dumped into the quarry to fill up old holes. To simplify the process, you design a system in which a granite block on a cart with steel wheels (weight w_1 , including both block and cart) is pulled uphill on steel rails by a dirt-filled bucket (weight w_2 , including both dirt and bucket) that descends vertically into the quarry (Fig. 5.5a). How must the weights w_1 and w_2 be related in order for the system to move with constant speed? Ignore friction in the pulley and wheels, and ignore the weight of the cable.

SOLUTION

IDENTIFY and SET UP: The cart and bucket each move with a constant velocity (in a straight line at constant speed). Hence each body is in equilibrium, and we can apply Newton's first law to each. Our target is an expression relating the weights w_1 and w_2 .

Figure 5.5b shows our idealized model for the system, and Figs. 5.5c and 5.5d show our free-body diagrams. The two forces on the bucket are its weight w_2 and an upward tension exerted by the cable. As for the cart on the ramp in Example 5.4, three forces act on the cart: its weight w_1 , a normal force of magnitude n exerted by the rails, and a tension force from the cable. (We're ignoring friction, so we assume that the rails exert no force on the cart parallel to the incline.) Note that we orient the axes differ-

How would the answers for T and n be affected if the car were being pulled up the ramp at a constant speed? This, too, is an equilibrium situation, since the car's velocity is constant. So the calculation is the same, and T and n have the same values as when the car is at rest. (It's true that T must be greater than $w \sin \alpha$ to *start* the car moving up the ramp, but that's not what we asked.)

ently for each body; the choices shown are the most convenient ones.

We're assuming that the cable has negligible weight, so the tension forces that the cable exerts on the cart and on the bucket have the same magnitude T . As we did for the car in Example 5.4, we represent the weight of the cart in terms of its x - and y -components.

EXECUTE: Applying $\sum F_y = 0$ to the bucket in Fig. 5.5c, we find

$$\sum F_y = T + (-w_2) = 0 \quad \text{so} \quad T = w_2$$

Applying $\sum F_x = 0$ to the cart (and block) in Fig. 5.5d, we get

$$\sum F_x = T + (-w_1 \sin 15^\circ) = 0 \quad \text{so} \quad T = w_1 \sin 15^\circ$$

Equating the two expressions for T , we find

$$w_2 = w_1 \sin 15^\circ = 0.26w_1$$

EVALUATE: Our analysis doesn't depend at all on the direction in which the cart and bucket move. Hence the system can move with constant speed in *either* direction if the weight of the dirt and bucket is 26% of the weight of the granite block and cart. What would happen if w_2 were greater than $0.26w_1$? If it were less than $0.26w_1$?

Notice that we didn't need the equation $\sum F_y = 0$ for the cart and block. Can you use this to show that $n = w_1 \cos 15^\circ$?

5.5 (a) The situation. (b) Our idealized model. (c), (d) Our free-body diagrams.

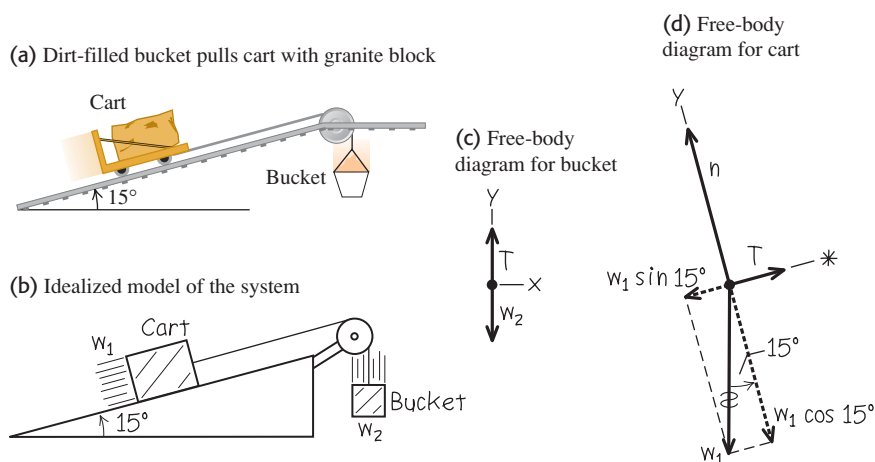

Test Your Understanding of Section 5.1 A traffic light of weight w hangs from two lightweight cables, one on each side of the light. Each cable hangs at a 45° angle from the horizontal. What is the tension in each cable? (i) $w/2$; (ii) $w/\sqrt{2}$; (iii) w ; (iv) $w\sqrt{2}$; (v) $2w$.



5.6 Correct and incorrect free-body diagrams for a falling body.

(a)



Only the force of gravity acts on this falling fruit.

(b) Correct free-body diagram

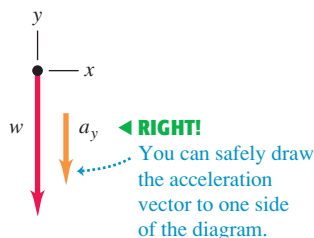

(c) Incorrect free-body diagram

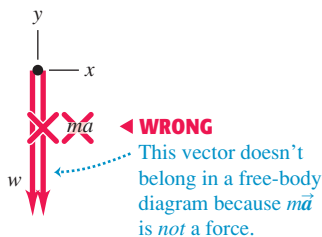

5.2 Using Newton's Second Law: Dynamics of Particles

We are now ready to discuss *dynamics* problems. In these problems, we apply Newton's second law to bodies on which the net force is *not* zero. These bodies are *not* in equilibrium and hence are accelerating. The net force on the body is equal to the mass of the body times its acceleration:

$$\sum \vec{F} = m\vec{a} \quad (\text{Newton's second law, vector form}) \quad (5.3)$$

We most often use this relationship in component form:

$$\sum F_x = ma_x \quad \sum F_y = ma_y \quad (\text{Newton's second law, component form}) \quad (5.4)$$

The following problem-solving strategy is very similar to Problem-Solving Strategy 5.1 for equilibrium problems in Section 5.1. Study it carefully, watch how we apply it in our examples, and use it when you tackle the end-of-chapter problems. You can solve *any* dynamics problem using this strategy.

CAUTION $m\vec{a}$ doesn't belong in free-body diagrams Remember that the quantity $m\vec{a}$ is the *result* of forces acting on a body, *not* a force itself; it's not a push or a pull exerted by anything in the body's environment. When you draw the free-body diagram for an accelerating body (like the fruit in Fig. 5.6a), make sure you *never* include the " $m\vec{a}$ force" because *there is no such force* (Fig. 5.6c). You should review Section 4.3 if you're not clear on this point. Sometimes we draw the acceleration vector \vec{a} *alongside* a free-body diagram, as in Fig. 5.6b. But we *never* draw the acceleration vector with its tail touching the body (a position reserved exclusively for the forces that act on the body). |

Problem-Solving Strategy 5.2 Newton's Second Law: Dynamics of Particles



IDENTIFY *the relevant concepts:* You have to use Newton's second law for *any* problem that involves forces acting on an accelerating body.

Identify the target variable—usually an acceleration or a force. If the target variable is something else, you'll need to select another concept to use. For example, suppose the target variable is how fast a sled is moving when it reaches the bottom of a hill. Newton's second law will let you find the sled's acceleration; you'll then use the constant-acceleration relationships from Section 2.4 to find velocity from acceleration.

SET UP *the problem* using the following steps:

1. Draw a simple sketch of the situation that shows each moving body. For each body, draw a free-body diagram that shows all the forces acting *on* the body. (The acceleration of a body is determined by the forces that act on it, *not* by the forces that it exerts on anything else.) Make sure you can answer the question "What other body is applying this force?" for each force in your diagram. Never include the quantity $m\vec{a}$ in your free-body diagram; it's not a force!
2. Label each force with an algebraic symbol for the force's *magnitude*. Usually, one of the forces will be the body's weight; it's usually best to label this as $w = mg$.
3. Choose your x - and y -coordinate axes for each body, and show them in its free-body diagram. Be sure to indicate the positive direction for each axis. If you know the direction of the acceleration, it usually simplifies things to take one positive axis along that direction. If your problem involves two or more bodies that

accelerate in different directions, you can use a different set of axes for each body.

4. In addition to Newton's second law, $\sum \vec{F} = m\vec{a}$, identify any other equations you might need. For example, you might need one or more of the equations for motion with constant acceleration. If more than one body is involved, there may be relationships among their motions; for example, they may be connected by a rope. Express any such relationships as equations relating the accelerations of the various bodies.

EXECUTE *the solution* as follows:

1. For each body, determine the components of the forces along each of the body's coordinate axes. When you represent a force in terms of its components, draw a wiggly line through the original force vector to remind you not to include it twice.
2. Make a list of all the known and unknown quantities. In your list, identify the target variable or variables.
3. For each body, write a separate equation for each component of Newton's second law, as in Eqs. (5.4). In addition, write any additional equations that you identified in step 4 of "Set Up." (You need as many equations as there are target variables.)
4. Do the easy part—the math! Solve the equations to find the target variable(s).

EVALUATE *your answer:* Does your answer have the correct units? (When appropriate, use the conversion $1 \text{ N} = 1 \text{ kg} \cdot \text{m/s}^2$.) Does it have the correct algebraic sign? When possible, consider particular values or extreme cases of quantities and compare the results with your intuitive expectations. Ask, "Does this result make sense?"

Example 5.6 Straight-line motion with a constant force

An iceboat is at rest on a frictionless horizontal surface (Fig. 5.7a). A wind is blowing along the direction of the runners so that 4.0 s after the iceboat is released, it is moving at 6.0 m/s (about 22 km/h, or 13 mi/h). What constant horizontal force F_W does the wind exert on the iceboat? The combined mass of iceboat and rider is 200 kg.

SOLUTION

IDENTIFY and SET UP: Our target variable is one of the forces (F_W) acting on the accelerating iceboat, so we need to use Newton's second law. The forces acting on the iceboat and rider (considered as a unit) are the weight w , the normal force n exerted by the surface, and the horizontal force F_W . Figure 5.7b shows the free-body diagram. The net force and hence the acceleration are to the right, so we chose the positive x -axis in this direction. The acceleration isn't given; we'll need to find it. Since the wind is assumed to exert a constant force, the resulting acceleration is constant and we can use one of the constant-acceleration formulas from Section 2.4.

5.7 (a) The situation. (b) Our free-body diagram.

(a) Iceboat and rider on frictionless ice



(b) Free-body diagram for iceboat and rider

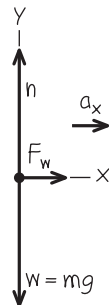

The iceboat starts at rest (its initial x -velocity is $v_{0x} = 0$) and it attains an x -velocity $v_x = 6.0$ m/s after an elapsed time $t = 4.0$ s. To relate the x -acceleration a_x to these quantities we use Eq. (2.8), $v_x = v_{0x} + a_x t$. There is no vertical acceleration, so we expect that the normal force on the iceboat is equal in magnitude to the iceboat's weight.

EXECUTE: The *known* quantities are the mass $m = 200$ kg, the initial and final x -velocities $v_{0x} = 0$ and $v_x = 6.0$ m/s, and the elapsed time $t = 4.0$ s. The three *unknown* quantities are the acceleration a_x , the normal force n , and the horizontal force F_W . Hence we need three equations.

The first two equations are the x - and y -equations for Newton's second law. The force F_W is in the positive x -direction, while the forces n and $w = mg$ are in the positive and negative y -directions, respectively. Hence we have

$$\begin{aligned}\sum F_x &= F_W = ma_x \\ \sum F_y &= n + (-mg) = 0 \quad \text{so} \quad n = mg\end{aligned}$$

The third equation is the constant-acceleration relationship, Eq. (2.8):

$$v_x = v_{0x} + a_x t$$

To find F_W , we first solve this third equation for a_x and then substitute the result into the $\sum F_x$ equation:

$$a_x = \frac{v_x - v_{0x}}{t} = \frac{6.0 \text{ m/s} - 0 \text{ m/s}}{4.0 \text{ s}} = 1.5 \text{ m/s}^2$$

$$F_W = ma_x = (200 \text{ kg})(1.5 \text{ m/s}^2) = 300 \text{ kg} \cdot \text{m/s}^2$$

Since $1 \text{ kg} \cdot \text{m/s}^2 = 1 \text{ N}$, the final answer is

$$F_W = 300 \text{ N (about 67 lb)}$$

EVALUATE: Our answers for F_W and n have the correct units for a force, and (as expected) the magnitude n of the normal force is equal to mg . Does it seem reasonable that the force F_W is substantially less than mg ?

Example 5.7 Straight-line motion with friction

Suppose a constant horizontal friction force with magnitude 100 N opposes the motion of the iceboat in Example 5.6. In this case, what constant force F_W must the wind exert on the iceboat to cause the same constant x -acceleration $a_x = 1.5 \text{ m/s}^2$?

SOLUTION

IDENTIFY and SET UP: Again the target variable is F_W . We are given the x -acceleration, so to find F_W all we need is Newton's second law. Figure 5.8 shows our new free-body diagram. The only difference from Fig. 5.7b is the addition of the friction force \vec{f} , which points opposite the motion. (Note that the *magnitude* $f = 100$ N is a positive quantity, but the *component* in the x -direction f_x is negative, equal to $-f$ or -100 N.) Because the wind must now overcome the friction force to yield the same acceleration as in Example 5.6, we expect our answer for F_W to be greater than the 300 N we found there.

5.8 Our free-body diagram for the iceboat and rider with a friction force \vec{f} opposing the motion.

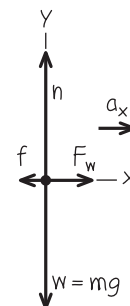

Continued

EXECUTE: Two forces now have x -components: the force of the wind and the friction force. The x -component of Newton's second law gives

$$\begin{aligned}\sum F_x &= F_W + (-f) = ma_x \\ F_W &= ma_x + f = (200 \text{ kg})(1.5 \text{ m/s}^2) + (100 \text{ N}) = 400 \text{ N}\end{aligned}$$

Example 5.8 Tension in an elevator cable

An elevator and its load have a combined mass of 800 kg (Fig. 5.9a). The elevator is initially moving downward at 10.0 m/s; it slows to a stop with constant acceleration in a distance of 25.0 m. What is the tension T in the supporting cable while the elevator is being brought to rest?

SOLUTION

IDENTIFY and SET UP: The target variable is the tension T , which we'll find using Newton's second law. As in Example 5.6, we'll determine the acceleration using a constant-acceleration formula. Our free-body diagram (Fig. 5.9b) shows two forces acting on the elevator: its weight w and the tension force T of the cable. The elevator is moving downward with decreasing speed, so its acceleration is upward; we chose the positive y -axis to be upward.

The elevator is moving in the negative y -direction, so its initial y -velocity v_{0y} and its y -displacement $y - y_0$ are both negative: $v_{0y} = -10.0 \text{ m/s}$ and $y - y_0 = -25.0 \text{ m}$. The final y -velocity is $v_y = 0$. To find the y -acceleration a_y from this information, we'll use Eq. (2.13) in the form $v_y^2 = v_{0y}^2 + 2a_y(y - y_0)$. Once we have a_y , we'll substitute it into the y -component of Newton's second law from Eqs. (5.4) and solve for T . The net force must be upward to give an upward acceleration, so we expect T to be greater than the weight $w = mg = (800 \text{ kg})(9.80 \text{ m/s}^2) = 7840 \text{ N}$.

EXECUTE: First let's write out Newton's second law. The tension force acts upward and the weight acts downward, so

$$\sum F_y = T + (-w) = ma_y$$

We solve for the target variable T :

$$T = w + ma_y = mg + ma_y = m(g + a_y)$$

EVALUATE: The required value of F_W is 100 N greater than in Example 5.6 because the wind must now push against an additional 100-N friction force.

5.9 (a) The situation. (b) Our free-body diagram.

(a) Descending elevator

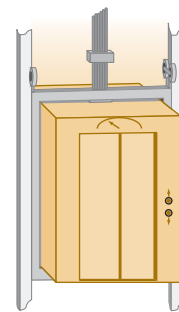

(b) Free-body diagram for elevator

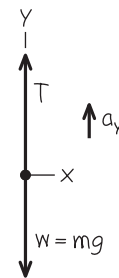

To determine a_y , we rewrite the constant-acceleration equation $v_y^2 = v_{0y}^2 + 2a_y(y - y_0)$:

$$a_y = \frac{v_y^2 - v_{0y}^2}{2(y - y_0)} = \frac{(0)^2 - (-10.0 \text{ m/s})^2}{2(-25.0 \text{ m})} = +2.00 \text{ m/s}^2$$

The acceleration is upward (positive), just as it should be.

Now we can substitute the acceleration into the equation for the tension:

$$\begin{aligned}T &= m(g + a_y) = (800 \text{ kg})(9.80 \text{ m/s}^2 + 2.00 \text{ m/s}^2) \\ &= 9440 \text{ N}\end{aligned}$$

EVALUATE: The tension is greater than the weight, as expected. Can you see that we would get the same answers for a_y and T if the elevator were moving *upward* and *gaining* speed at a rate of 2.00 m/s²?

Example 5.9 Apparent weight in an accelerating elevator

A 50.0-kg woman stands on a bathroom scale while riding in the elevator in Example 5.8. What is the reading on the scale?

SOLUTION

IDENTIFY and SET UP: The scale (Fig. 5.10a) reads the magnitude of the downward force exerted *by* the woman *on* the scale. By Newton's third law, this equals the magnitude of the upward normal force exerted *by* the scale *on* the woman. Hence our target variable is the magnitude n of the normal force. We'll find n by applying Newton's second law to the woman. We already know her acceleration; it's the same as the acceleration of the elevator, which we calculated in Example 5.8.

Figure 5.10b shows our free-body diagram for the woman. The forces acting on her are the normal force n exerted by the scale and her weight $w = mg = (50.0 \text{ kg})(9.80 \text{ m/s}^2) = 490 \text{ N}$.

5.10 (a) The situation. (b) Our free-body diagram.

(a) Woman in a descending elevator

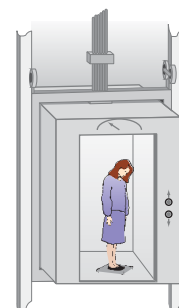

(b) Free-body diagram for woman

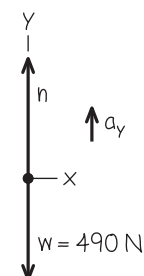

(The tension force, which played a major role in Example 5.8, doesn't appear here because it doesn't act on the woman.) From Example 5.8, the y -acceleration of the elevator and of the woman is $a_y = +2.00 \text{ m/s}^2$. As in Example 5.8, the upward force on the body accelerating upward (in this case, the normal force on the woman) will have to be greater than the body's weight to produce the upward acceleration.

EXECUTE: Newton's second law gives

$$\begin{aligned}\sum F_y &= n + (-mg) = ma_y \\ n &= mg + ma_y = m(g + a_y) \\ &= (50.0 \text{ kg})(9.80 \text{ m/s}^2 + 2.00 \text{ m/s}^2) = 590 \text{ N}\end{aligned}$$

EVALUATE: Our answer for n means that while the elevator is stopping, the scale pushes up on the woman with a force of 590 N. By Newton's third law, she pushes down on the scale with the same force. So the scale reads 590 N, which is 100 N more than her actual

weight. The scale reading is called the passenger's **apparent weight**. The woman *feels* the floor pushing up harder on her feet than when the elevator is stationary or moving with constant velocity.

What would the woman feel if the elevator were accelerating *downward*, so that $a_y = -2.00 \text{ m/s}^2$? This would be the case if the elevator were moving upward with decreasing speed or moving downward with increasing speed. To find the answer for this situation, we just insert the new value of a_y in our equation for n :

$$\begin{aligned}n &= m(g + a_y) = (50.0 \text{ kg})[9.80 \text{ m/s}^2 + (-2.00 \text{ m/s}^2)] \\ &= 390 \text{ N}\end{aligned}$$

Now the woman feels as though she weighs only 390 N, or 100 N less than her actual weight w .

You can feel these effects yourself; try taking a few steps in an elevator that is coming to a stop after descending (when your apparent weight is greater than w) or coming to a stop after ascending (when your apparent weight is less than w).

Apparent Weight and Apparent Weightlessness

Let's generalize the result of Example 5.9. When a passenger with mass m rides in an elevator with y -acceleration a_y , a scale shows the passenger's apparent weight to be

$$n = m(g + a_y)$$

When the elevator is accelerating upward, a_y is positive and n is greater than the passenger's weight $w = mg$. When the elevator is accelerating downward, a_y is negative and n is less than the weight. If the passenger doesn't know the elevator is accelerating, she may feel as though her weight is changing; indeed, this is just what the scale shows.

The extreme case occurs when the elevator has a downward acceleration $a_y = -g$ —that is, when it is in free fall. In that case $n = 0$ and the passenger *seems* to be weightless. Similarly, an astronaut orbiting the earth with a spacecraft experiences *apparent weightlessness* (Fig. 5.11). In each case, the person is not truly weightless because a gravitational force still acts. But the person's sensations in this free-fall condition are exactly the same as though the person were in outer space with no gravitational force at all. In both cases the person and the vehicle (elevator or spacecraft) fall together with the same acceleration g , so nothing pushes the person against the floor or walls of the vehicle.

5.11 Astronauts in orbit feel “weightless” because they have the same acceleration as their spacecraft—not because they are “outside the pull of the earth's gravity.” (If no gravity acted on them, the astronauts and their spacecraft wouldn't remain in orbit, but would fly off into deep space.)



Example 5.10 Acceleration down a hill

A toboggan loaded with students (total weight w) slides down a snow-covered slope. The hill slopes at a constant angle α , and the toboggan is so well waxed that there is virtually no friction. What is its acceleration?

SOLUTION

IDENTIFY and SET UP: Our target variable is the acceleration, which we'll find using Newton's second law. There is no friction, so only two forces act on the toboggan: its weight w and the normal force n exerted by the hill.

Figure 5.12 shows our sketch and free-body diagram. As in Example 5.4, the surface is inclined, so the normal force is not vertical and is not equal in magnitude to the weight. Hence we must use both components of $\sum \vec{F} = m\vec{a}$ in Eqs. (5.4). We take axes parallel

5.12 Our sketches for this problem.

(a) The situation

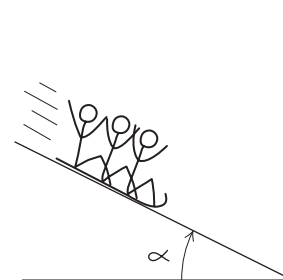

(b) Free-body diagram for toboggan

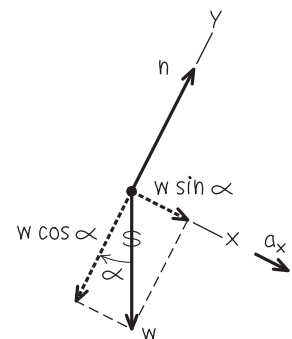

Continued

and perpendicular to the surface of the hill, so that the acceleration (which is parallel to the hill) is along the positive x -direction.

EXECUTE: The normal force has only a y -component, but the weight has both x - and y -components: $w_x = w \sin \alpha$ and $w_y = -w \cos \alpha$. (In Example 5.4 we had $w_x = -w \sin \alpha$. The difference is that the positive x -axis was uphill in Example 5.4 but is downhill in Fig. 5.12b.) The wiggly line in Fig. 5.12b reminds us that we have resolved the weight into its components. The acceleration is purely in the $+x$ -direction, so $a_y = 0$. Newton's second law in component form then tells us that

$$\begin{aligned}\sum F_x &= w \sin \alpha = ma_x \\ \sum F_y &= n - w \cos \alpha = ma_y = 0\end{aligned}$$

Since $w = mg$, the x -component equation tells us that $mg \sin \alpha = ma_x$, or

$$a_x = g \sin \alpha$$

Note that we didn't need the y -component equation to find the acceleration. That's part of the beauty of choosing the x -axis to lie along the acceleration direction! The y -equation tells us the mag-

nitude of the normal force exerted by the hill on the toboggan:

$$n = w \cos \alpha = mg \cos \alpha$$

EVALUATE: Notice that the normal force n is not equal to the toboggan's weight (compare Example 5.4). Notice also that the mass m does not appear in our result for the acceleration. That's because the downhill force on the toboggan (a component of the weight) is proportional to m , so the mass cancels out when we use $\sum F_x = ma_x$ to calculate a_x . Hence *any* toboggan, regardless of its mass, slides down a frictionless hill with acceleration $g \sin \alpha$.

If the plane is horizontal, $\alpha = 0$ and $a_x = 0$ (the toboggan does not accelerate); if the plane is vertical, $\alpha = 90^\circ$ and $a_x = g$ (the toboggan is in free fall).

CAUTION Common free-body diagram errors Figure 5.13 shows both the correct way (Fig. 5.13a) and a common *incorrect* way (Fig. 5.13b) to draw the free-body diagram for the toboggan. The diagram in Fig. 5.13b is wrong for two reasons: The normal force must be drawn perpendicular to the surface, and there's no such thing as the " $m\vec{a}$ force." If you remember that "normal" means "perpendicular" and that $m\vec{a}$ is not itself a force, you'll be well on your way to always drawing correct free-body diagrams. **|**

5.13 Correct and incorrect free-body diagrams for a toboggan on a frictionless hill.

(a) Correct free-body diagram for the sled

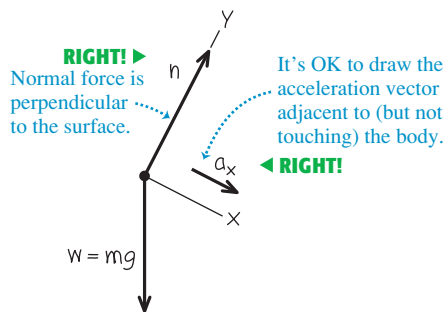

(b) Incorrect free-body diagram for the sled

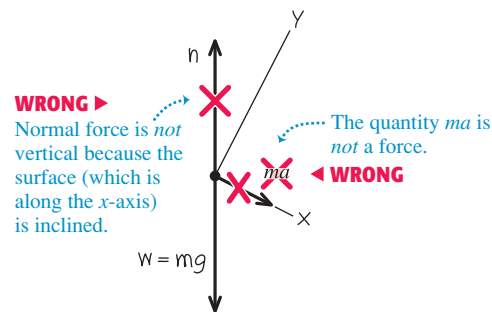

Example 5.11 Two bodies with the same acceleration

You push a 1.00-kg food tray through the cafeteria line with a constant 9.0-N force. The tray pushes on a 0.50-kg carton of milk (Fig. 5.14a). The tray and carton slide on a horizontal surface so greasy that friction can be neglected. Find the acceleration of the tray and carton and the horizontal force that the tray exerts on the carton.

SOLUTION

IDENTIFY and SET UP: Our *two* target variables are the acceleration of the tray–carton system and the force of the tray on the carton. We'll use Newton's second law to get two equations, one for each target variable. We set up and solve the problem in two ways.

Method 1: We treat the milk carton (mass m_C) and tray (mass m_T) as separate bodies, each with its own free-body diagram (Figs. 5.14b and 5.14c). The force F that you exert on the tray doesn't appear in the free-body diagram for the carton, which is accelerated by the force (of magnitude $F_{T \text{ on } C}$) exerted on it by the tray. By Newton's third law, the carton exerts a force of equal magnitude on the tray: $F_{C \text{ on } T} = F_{T \text{ on } C}$. We take the acceleration to

be in the positive x -direction; both the tray and milk carton move with the same x -acceleration a_x .

Method 2: We treat the tray and milk carton as a composite body of mass $m = m_T + m_C = 1.50$ kg (Fig. 5.14d). The only horizontal force acting on this body is the force F that you exert. The forces $F_{T \text{ on } C}$ and $F_{C \text{ on } T}$ don't come into play because they're *internal* to this composite body, and Newton's second law tells us that only *external* forces affect a body's acceleration (see Section 4.3). To find the magnitude $F_{T \text{ on } C}$ we'll again apply Newton's second law to the carton, as in Method 1.

EXECUTE: Method 1: The x -component equations of Newton's second law are

$$\begin{aligned}\text{Tray:} \quad & \sum F_x = F - F_{C \text{ on } T} = F - F_{T \text{ on } C} = m_T a_x \\ \text{Carton:} \quad & \sum F_x = F_{T \text{ on } C} = m_C a_x\end{aligned}$$

These are two simultaneous equations for the two target variables a_x and $F_{T \text{ on } C}$. (Two equations are all we need, which means that

5.14 Pushing a food tray and milk carton in the cafeteria line.

(a) A milk carton and a food tray

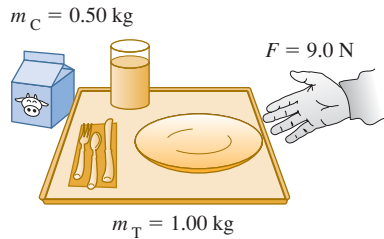

(b) Free-body diagram for milk carton

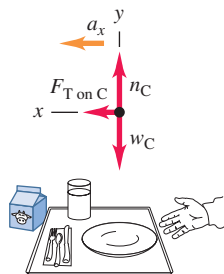

(c) Free-body diagram for food tray

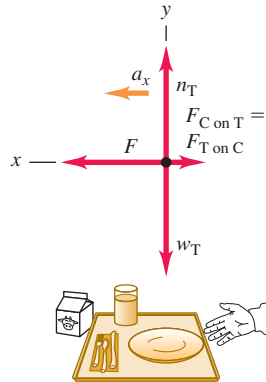

(d) Free-body diagram for carton and tray as a composite body

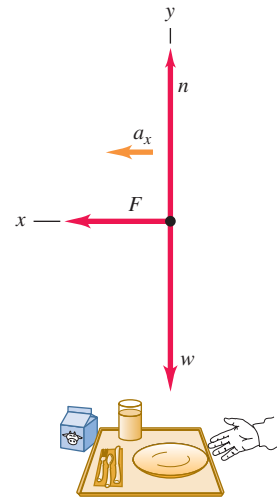

the y -components don't play a role in this example.) An easy way to solve the two equations for a_x is to add them; this eliminates $F_{T \text{ on } C}$, giving

$$F = m_T a_x + m_C a_x = (m_T + m_C) a_x$$

and

$$a_x = \frac{F}{m_T + m_C} = \frac{9.0 \text{ N}}{1.00 \text{ kg} + 0.50 \text{ kg}} = 6.0 \text{ m/s}^2 = 0.61g$$

Substituting this value into the carton equation gives

$$F_{T \text{ on } C} = m_C a_x = (0.50 \text{ kg})(6.0 \text{ m/s}^2) = 3.0 \text{ N}$$

Method 2: The x -component of Newton's second law for the composite body of mass m is

$$\sum F_x = F = m a_x$$

The acceleration of this composite body is

$$a_x = \frac{F}{m} = \frac{9.0 \text{ N}}{1.50 \text{ kg}} = 6.0 \text{ m/s}^2$$

Then, looking at the milk carton by itself, we see that to give it an acceleration of 6.0 m/s^2 requires that the tray exert a force

$$F_{T \text{ on } C} = m_C a_x = (0.50 \text{ kg})(6.0 \text{ m/s}^2) = 3.0 \text{ N}$$

EVALUATE: The answers are the same with both methods. To check the answers, note that there are different forces on the two sides of the tray: $F = 9.0 \text{ N}$ on the right and $F_{C \text{ on } T} = 3.0 \text{ N}$ on the left. The net horizontal force on the tray is $F - F_{C \text{ on } T} = 6.0 \text{ N}$, exactly enough to accelerate a 1.00-kg tray at 6.0 m/s^2 .

Treating two bodies as a single, composite body works *only* if the two bodies have the same magnitude *and* direction of acceleration. If the accelerations are different we must treat the two bodies separately, as in the next example.

Example 5.12 Two bodies with the same magnitude of acceleration

Figure 5.15a shows an air-track glider with mass m_1 moving on a level, frictionless air track in the physics lab. The glider is connected to a lab weight with mass m_2 by a light, flexible, non-stretching string that passes over a stationary, frictionless pulley. Find the acceleration of each body and the tension in the string.

SOLUTION

IDENTIFY and SET UP: The glider and weight are accelerating, so again we must use Newton's second law. Our three target variables are the tension T in the string and the accelerations of the two bodies.

The two bodies move in different directions—one horizontal, one vertical—so we can't consider them together as we did the bodies in Example 5.11. Figures 5.15b and 5.15c show our free-body diagrams and coordinate systems. It's convenient to have both bodies accelerate in the positive axis directions,

5.15 (a) The situation. (b), (c) Our free-body diagrams.

(a) Apparatus

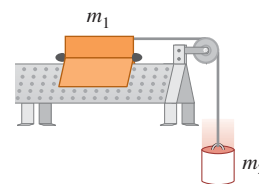

(b) Free-body diagram for glider

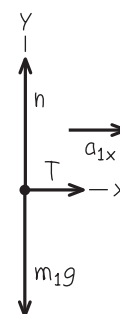

(c) Free-body diagram for weight

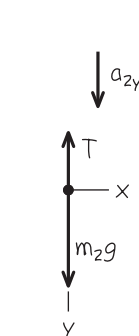

Continued

so we chose the positive y -direction for the lab weight to be downward.

We consider the string to be massless and to slide over the pulley without friction, so the tension T in the string is the same throughout and it applies a force of the same magnitude T to each body. (You may want to review Conceptual Example 4.10, in which we discussed the tension force exerted by a massless string.) The weights are m_1g and m_2g .

While the *directions* of the two accelerations are different, their *magnitudes* are the same. (That's because the string doesn't stretch, so the two bodies must move equal distances in equal times and their speeds at any instant must be equal. When the speeds change, they change at the same rate, so the accelerations of the two bodies must have the same magnitude a .) We can express this relationship as $a_{1x} = a_{2y} = a$, which means that we have only *two* target variables: a and the tension T .

What results do we expect? If $m_1 = 0$ (or, approximately, for m_1 much less than m_2) the lab weight will fall freely with acceleration g , and the tension in the string will be zero. For $m_2 = 0$ (or, approximately, for m_2 much less than m_1) we expect zero acceleration and zero tension.

EXECUTE: Newton's second law gives

$$\begin{aligned} \text{Glider:} \quad \sum F_x &= T = m_1 a_{1x} = m_1 a \\ \text{Glider:} \quad \sum F_y &= n + (-m_1 g) = m_1 a_{1y} = 0 \\ \text{Lab weight:} \quad \sum F_y &= m_2 g + (-T) = m_2 a_{2y} = m_2 a \end{aligned}$$

(There are no forces on the lab weight in the x -direction.) In these equations we've used $a_{1y} = 0$ (the glider doesn't accelerate vertically) and $a_{1x} = a_{2y} = a$.

The x -equation for the glider and the equation for the lab weight give us two simultaneous equations for T and a :

$$\begin{aligned} \text{Glider:} \quad T &= m_1 a \\ \text{Lab weight:} \quad m_2 g - T &= m_2 a \end{aligned}$$

We add the two equations to eliminate T , giving

$$m_2 g = m_1 a + m_2 a = (m_1 + m_2) a$$

and so the magnitude of each body's acceleration is

$$a = \frac{m_2}{m_1 + m_2} g$$

Substituting this back into the glider equation $T = m_1 a$, we get

$$T = \frac{m_1 m_2}{m_1 + m_2} g$$

EVALUATE: The acceleration is in general less than g , as you might expect; the string tension keeps the lab weight from falling freely. The tension T is *not* equal to the weight $m_2 g$ of the lab weight, but is *less* by a factor of $m_1/(m_1 + m_2)$. If T were equal to $m_2 g$, then the lab weight would be in equilibrium, and it isn't.

As predicted, the acceleration is equal to g for $m_1 = 0$ and equal to zero for $m_2 = 0$, and $T = 0$ for either $m_1 = 0$ or $m_2 = 0$.

CAUTION **Tension and weight may not be equal** It's a common mistake to assume that if an object is attached to a vertical string, the string tension must be equal to the object's weight. That was the case in Example 5.5, where the acceleration was zero, but it's not the case in this example! The only safe approach is *always* to treat the tension as a variable, as we did here. **|**

MasteringPHYSICS®

PhET: Lunar Lander

ActivPhysics 2.1.5: Car Race

ActivPhysics 2.2: Lifting a Crate

ActivPhysics 2.3: Lowering a Crate

ActivPhysics 2.4: Rocket Blasts Off

ActivPhysics 2.5: Modified Atwood Machine

5.16 The sport of ice hockey depends on having the right amount of friction between a player's skates and the ice. If there were too much friction, the players would move too slowly; if there were too little friction, they would fall over.



Test Your Understanding of Section 5.2 Suppose you hold the glider in Example 5.12 so that it and the weight are initially at rest. You give the glider a push to the left in Fig. 5.15a and then release it. The string remains taut as the glider moves to the left, comes instantaneously to rest, then moves to the right. At the instant the glider has zero velocity, what is the tension in the string? (i) greater than in Example 5.12; (ii) the same as in Example 5.12; (iii) less than in Example 5.12, but greater than zero; (iv) zero. **|**

5.3 Frictional Forces

We've seen several problems where a body rests or slides on a surface that exerts forces on the body. Whenever two bodies interact by direct contact (touching) of their surfaces, we describe the interaction in terms of *contact forces*. The normal force is one example of a contact force; in this section we'll look in detail at another contact force, the force of friction.

Friction is important in many aspects of everyday life. The oil in a car engine minimizes friction between moving parts, but without friction between the tires and the road we couldn't drive or turn the car. Air drag—the frictional force exerted by the air on a body moving through it—decreases automotive fuel economy but makes parachutes work. Without friction, nails would pull out, light bulbs would unscrew effortlessly, and ice hockey would be hopeless (Fig. 5.16).

Kinetic and Static Friction

When you try to slide a heavy box of books across the floor, the box doesn't move at all unless you push with a certain minimum force. Then the box starts moving, and you can usually keep it moving with less force than you needed to

get it started. If you take some of the books out, you need less force than before to get it started or keep it moving. What general statements can we make about this behavior?

First, when a body rests or slides on a surface, we can think of the surface as exerting a single contact force on the body, with force components perpendicular and parallel to the surface (Fig. 5.17). The perpendicular component vector is the normal force, denoted by \vec{n} . The component vector parallel to the surface (and perpendicular to \vec{n}) is the **friction force**, denoted by \vec{f} . If the surface is frictionless, then \vec{f} is zero but there is still a normal force. (Frictionless surfaces are an unattainable idealization, like a massless rope. But we can approximate a surface as frictionless if the effects of friction are negligibly small.) The direction of the friction force is always such as to oppose relative motion of the two surfaces.

The kind of friction that acts when a body slides over a surface is called a **kinetic friction force** \vec{f}_k . The adjective “kinetic” and the subscript “k” remind us that the two surfaces are moving relative to each other. The *magnitude* of the kinetic friction force usually increases when the normal force increases. This is why it takes more force to slide a box across the floor when it’s full of books than when it’s empty. Automotive brakes use the same principle: The harder the brake pads are squeezed against the rotating brake disks, the greater the braking effect. In many cases the magnitude of the kinetic friction force f_k is found experimentally to be approximately *proportional* to the magnitude n of the normal force. In such cases we represent the relationship by the equation

$$f_k = \mu_k n \quad (\text{magnitude of kinetic friction force}) \quad (5.5)$$

where μ_k (pronounced “mu-sub-k”) is a constant called the **coefficient of kinetic friction**. The more slippery the surface, the smaller this coefficient. Because it is a quotient of two force magnitudes, μ_k is a pure number without units.

CAUTION Friction and normal forces are always perpendicular Remember that Eq. (5.5) is *not* a vector equation because \vec{f}_k and \vec{n} are always perpendicular. Rather, it is a scalar relationship between the magnitudes of the two forces. **I**

Equation (5.5) is only an approximate representation of a complex phenomenon. On a microscopic level, friction and normal forces result from the intermolecular forces (fundamentally electrical in nature) between two rough surfaces at points where they come into contact (Fig. 5.18). As a box slides over the floor, bonds between the two surfaces form and break, and the total number of such bonds varies; hence the kinetic friction force is not perfectly constant. Smoothing the surfaces can actually increase friction, since more molecules are able to interact and bond; bringing two smooth surfaces of the same metal together can cause a “cold weld.” Lubricating oils work because an oil film between two surfaces (such as the pistons and cylinder walls in a car engine) prevents them from coming into actual contact.

Table 5.1 lists some representative values of μ_k . Although these values are given with two significant figures, they are only approximate, since friction forces can also depend on the speed of the body relative to the surface. For now we’ll ignore this effect and assume that μ_k and f_k are independent of speed, in order to concentrate on the simplest cases. Table 5.1 also lists coefficients of static friction; we’ll define these shortly.

Friction forces may also act when there is *no* relative motion. If you try to slide a box across the floor, the box may not move at all because the floor exerts an equal and opposite friction force on the box. This is called a **static friction force** \vec{f}_s . In Fig. 5.19a, the box is at rest, in equilibrium, under the action of its weight \vec{w} and the upward normal force \vec{n} . The normal force is equal in magnitude to the weight ($n = w$) and is exerted on the box by the floor. Now we tie a rope

5.17 When a block is pushed or pulled over a surface, the surface exerts a contact force on it.

The friction and normal forces are really components of a single contact force.

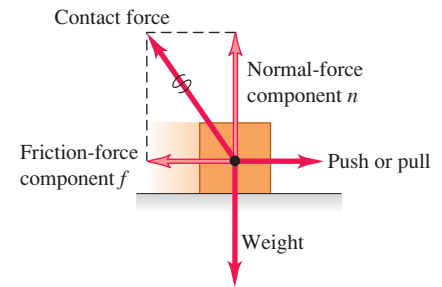

5.18 The normal and friction forces arise from interactions between molecules at high points on the surfaces of the block and the floor.

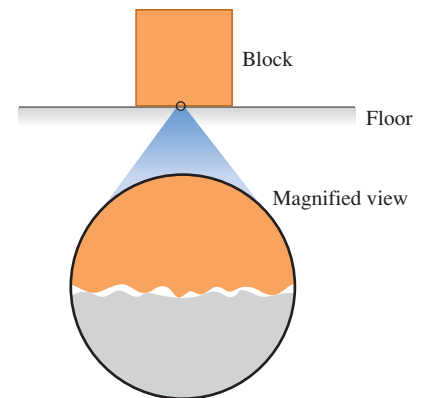

On a microscopic level, even smooth surfaces are rough; they tend to catch and cling.

Table 5.1 Approximate Coefficients of Friction

Materials	Coefficient of Static Friction, μ_s	Coefficient of Kinetic Friction, μ_k
Steel on steel	0.74	0.57
Aluminum on steel	0.61	0.47
Copper on steel	0.53	0.36
Brass on steel	0.51	0.44
Zinc on cast iron	0.85	0.21
Copper on cast iron	1.05	0.29
Glass on glass	0.94	0.40
Copper on glass	0.68	0.53
Teflon on Teflon	0.04	0.04
Teflon on steel	0.04	0.04
Rubber on concrete (dry)	1.0	0.8
Rubber on concrete (wet)	0.30	0.25



5.19 (a), (b), (c) When there is no relative motion, the magnitude of the static friction force f_s is less than or equal to $\mu_s n$. (d) When there is relative motion, the magnitude of the kinetic friction force f_k equals $\mu_k n$. (e) A graph of the friction force magnitude f as a function of the magnitude T of the applied force. The kinetic friction force varies somewhat as intermolecular bonds form and break.

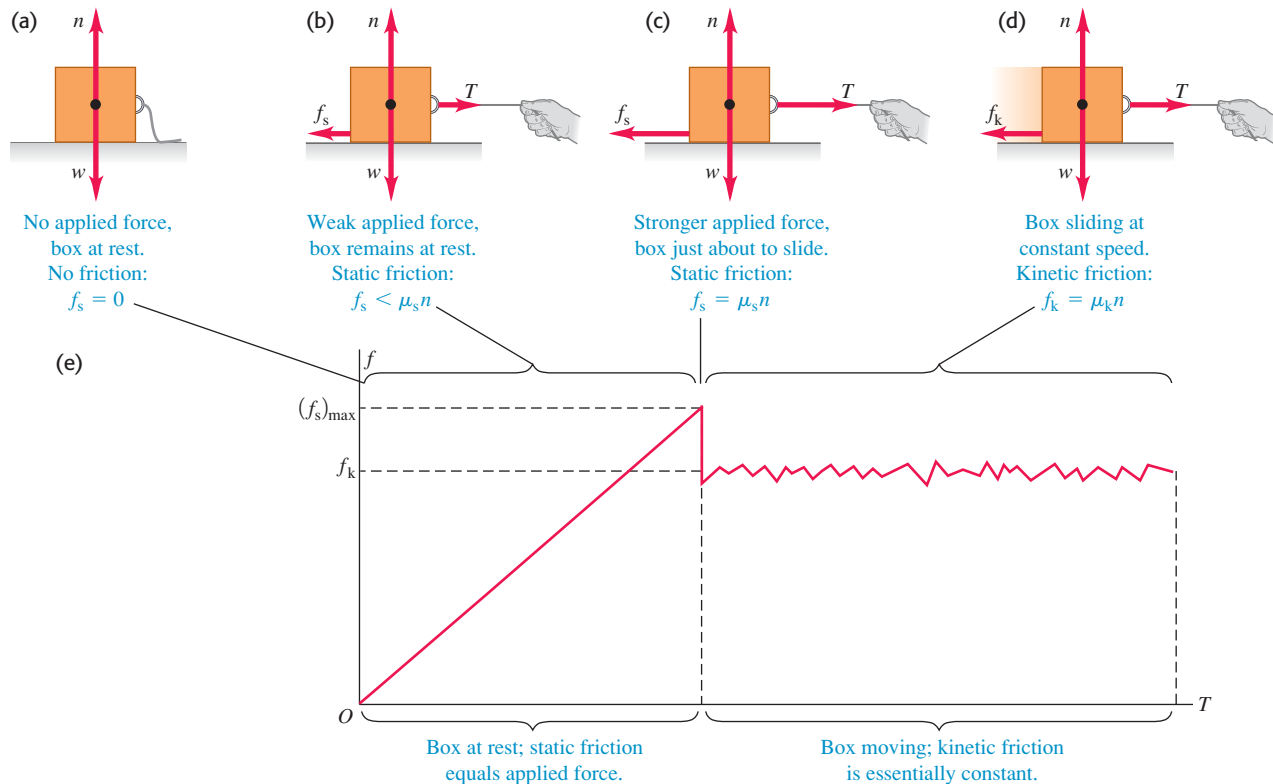

to the box (Fig. 5.19b) and gradually increase the tension T in the rope. At first the box remains at rest because the force of static friction f_s also increases and stays equal in magnitude to T .

At some point T becomes greater than the maximum static friction force f_s the surface can exert. Then the box “breaks loose” (the tension T is able to break the bonds between molecules in the surfaces of the box and floor) and starts to slide. Figure 5.19c shows the forces when T is at this critical value. If T exceeds this value, the box is no longer in equilibrium. For a given pair of surfaces the maximum value of f_s depends on the normal force. Experiment shows that in many cases this maximum value, called $(f_s)_{\max}$, is approximately *proportional* to n ; we call the proportionality factor μ_s the **coefficient of static friction**. Table 5.1 lists some representative values of μ_s . In a particular situation, the actual force of static friction can have any magnitude between zero (when there is no other force parallel to the surface) and a maximum value given by $\mu_s n$. In symbols,

$$f_s \leq \mu_s n \quad (\text{magnitude of static friction force}) \quad (5.6)$$

Like Eq. (5.5), this is a relationship between magnitudes, *not* a vector relationship. The equality sign holds only when the applied force T has reached the critical value at which motion is about to start (Fig. 5.19c). When T is less than this value (Fig. 5.19b), the inequality sign holds. In that case we have to use the equilibrium conditions ($\sum \vec{F} = \mathbf{0}$) to find f_s . If there is no applied force ($T = 0$) as in Fig. 5.19a, then there is no static friction force either ($f_s = 0$).

As soon as the box starts to slide (Fig. 5.19d), the friction force usually *decreases* (Fig. 5.19e); it's easier to keep the box moving than to start it moving. Hence the coefficient of kinetic friction is usually *less* than the coefficient of static friction for any given pair of surfaces, as Table 5.1 shows.

Application Static Friction and Windshield Wipers

The squeak of windshield wipers on dry glass is a stick-slip phenomenon. The moving wiper blade sticks to the glass momentarily, then slides when the force applied to the blade by the wiper motor overcomes the maximum force of static friction. When the glass is wet from rain or windshield cleaning solution, friction is reduced and the wiper blade doesn't stick.



In some situations the surfaces will alternately stick (static friction) and slip (kinetic friction). This is what causes the horrible sound made by chalk held at the wrong angle while writing on the blackboard and the shriek of tires sliding on asphalt pavement. A more positive example is the motion of a violin bow against the string.

When a body slides on a layer of gas, friction can be made very small. In the linear air track used in physics laboratories, the gliders are supported on a layer of air. The frictional force is velocity dependent, but at typical speeds the effective coefficient of friction is of the order of 0.001.

MasteringPHYSICS®

PhET: Forces in 1 Dimension

PhET: Friction

PhET: The Ramp

ActivPhysics 2.5: Truck Pulls Crate

ActivPhysics 2.6: Pushing a Crate Up a Wall

ActivPhysics 2.7: Skier Goes Down a Slope

ActivPhysics 2.8: Skier and Rope Tow

ActivPhysics 2.10: Truck Pulls Two Crates

Example 5.13 Friction in horizontal motion

You want to move a 500-N crate across a level floor. To start the crate moving, you have to pull with a 230-N horizontal force. Once the crate “breaks loose” and starts to move, you can keep it moving at constant velocity with only 200 N. What are the coefficients of static and kinetic friction?

SOLUTION

IDENTIFY and SET UP: The crate is in equilibrium both when it is at rest and when it is moving with constant velocity, so we use Newton’s first law, as expressed by Eqs. (5.2). We use Eqs. (5.5) and (5.6) to find the target variables μ_s and μ_k .

Figures 5.20a and 5.20b show our sketch and free-body diagram for the instant just before the crate starts to move, when the static friction force has its maximum possible value

$(f_s)_{\max} = \mu_s n$. Once the crate is moving, the friction force changes to its kinetic form (Fig. 5.20c). In both situations, four forces act on the crate: the downward weight (magnitude $w = 500$ N), the upward normal force (magnitude n) exerted by the floor, a tension force (magnitude T) to the right exerted by the rope, and a friction force to the left exerted by the ground. Because the rope in Fig. 5.20a is in equilibrium, the tension is the same at both ends. Hence the tension force that the rope exerts on the crate has the same magnitude as the force you exert on the rope. Since it’s easier to keep the crate moving than to start it moving, we expect that $\mu_k < \mu_s$.

EXECUTE: Just before the crate starts to move (Fig. 5.20b), we have from Eqs. (5.2)

$$\begin{aligned}\sum F_x &= T + (-(f_s)_{\max}) = 0 & \text{so } (f_s)_{\max} &= T = 230 \text{ N} \\ \sum F_y &= n + (-w) = 0 & \text{so } n &= w = 500 \text{ N}\end{aligned}$$

Now we solve Eq. (5.6), $(f_s)_{\max} = \mu_s n$, for the value of μ_s :

$$\mu_s = \frac{(f_s)_{\max}}{n} = \frac{230 \text{ N}}{500 \text{ N}} = 0.46$$

After the crate starts to move (Fig. 5.20c) we have

$$\begin{aligned}\sum F_x &= T + (-f_k) = 0 & \text{so } f_k &= T = 200 \text{ N} \\ \sum F_y &= n + (-w) = 0 & \text{so } n &= w = 500 \text{ N}\end{aligned}$$

Using $f_k = \mu_k n$ from Eq. (5.5), we find

$$\mu_k = \frac{f_k}{n} = \frac{200 \text{ N}}{500 \text{ N}} = 0.40$$

EVALUATE: As expected, the coefficient of kinetic friction is less than the coefficient of static friction.

5.20 Our sketches for this problem.

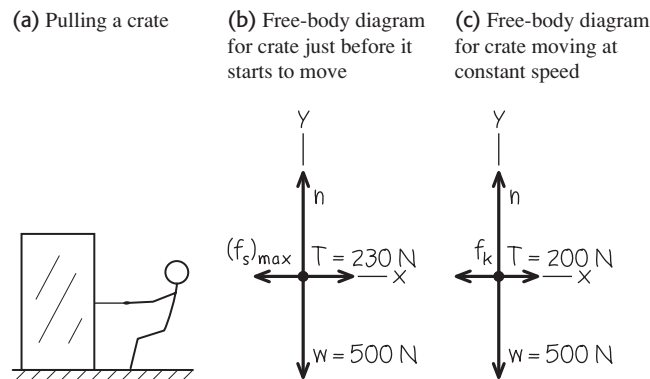

Example 5.14 Static friction can be less than the maximum

In Example 5.13, what is the friction force if the crate is at rest on the surface and a horizontal force of 50 N is applied to it?

SOLUTION

IDENTIFY and SET UP: The applied force is less than the maximum force of static friction, $(f_s)_{\max} = 230$ N. Hence the crate remains at rest and the net force acting on it is zero. The target variable is the magnitude f_s of the friction force. The free-body diagram is the

same as in Fig. 5.20b, but with $(f_s)_{\max}$ replaced by f_s and $T = 230$ N replaced by $T = 50$ N.

EXECUTE: From the equilibrium conditions, Eqs. (5.2), we have

$$\sum F_x = T + (-f_s) = 0 \quad \text{so} \quad f_s = T = 50 \text{ N}$$

EVALUATE: The friction force can prevent motion for any horizontal applied force up to $(f_s)_{\max} = \mu_s n = 230$ N. Below that value, f_s has the same magnitude as the applied force.

Example 5.15 Minimizing kinetic friction

In Example 5.13, suppose you move the crate by pulling upward on the rope at an angle of 30° above the horizontal. How hard must you pull to keep it moving with constant velocity? Assume that $\mu_k = 0.40$.

SOLUTION

IDENTIFY and SET UP: The crate is in equilibrium because its velocity is constant, so we again apply Newton's first law. Since the crate is in motion, the floor exerts a *kinetic* friction force. The target variable is the magnitude T of the tension force.

Figure 5.21 shows our sketch and free-body diagram. The kinetic friction force f_k is still equal to $\mu_k n$, but now the normal

5.21 Our sketches for this problem.

(b) Free-body diagram for moving crate

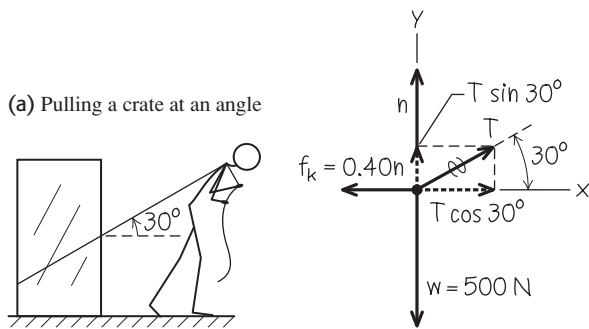

force n is *not* equal in magnitude to the crate's weight. The force exerted by the rope has a vertical component that tends to lift the crate off the floor; this *reduces* n and so reduces f_k .

EXECUTE: From the equilibrium conditions and the equation $f_k = \mu_k n$, we have

$$\begin{aligned}\sum F_x &= T \cos 30^\circ + (-f_k) = 0 \quad \text{so} \quad T \cos 30^\circ = \mu_k n \\ \sum F_y &= T \sin 30^\circ + n + (-w) = 0 \quad \text{so} \quad n = w - T \sin 30^\circ\end{aligned}$$

These are two equations for the two unknown quantities T and n . One way to find T is to substitute the expression for n in the second equation into the first equation and then solve the resulting equation for T :

$$T \cos 30^\circ = \mu_k (w - T \sin 30^\circ)$$

$$T = \frac{\mu_k w}{\cos 30^\circ + \mu_k \sin 30^\circ} = 188 \text{ N}$$

We can substitute this result into either of the original equations to obtain n . If we use the second equation, we get

$$n = w - T \sin 30^\circ = (500 \text{ N}) - (188 \text{ N}) \sin 30^\circ = 406 \text{ N}$$

EVALUATE: As expected, the normal force is less than the 500-N weight of the box. It turns out that the tension required to keep the crate moving at constant speed is a little less than the 200-N force needed when you pulled horizontally in Example 5.13. Can you find an angle where the required pull is *minimum*? (See Challenge Problem 5.121.)

Example 5.16 Toboggan ride with friction I

Let's go back to the toboggan we studied in Example 5.10. The wax has worn off, so there is now a nonzero coefficient of kinetic friction μ_k . The slope has just the right angle to make the toboggan slide with constant velocity. Find this angle in terms of w and μ_k .

SOLUTION

IDENTIFY and SET UP: Our target variable is the slope angle α . The toboggan is in equilibrium because its velocity is constant, so we use Newton's first law in the form of Eqs. (5.2).

Three forces act on the toboggan: its weight, the normal force, and the kinetic friction force. The motion is downhill, so the friction force (which opposes the motion) is directed uphill. Figure 5.22 shows our sketch and free-body diagram (compare Fig. 5.12b in Example 5.10). The magnitude of the kinetic friction force is $f_k = \mu_k n$. We expect that the greater the value of μ_k , the steeper will be the required slope.

EXECUTE: The equilibrium conditions are

$$\begin{aligned}\sum F_x &= w \sin \alpha + (-f_k) = w \sin \alpha - \mu_k n = 0 \\ \sum F_y &= n + (-w \cos \alpha) = 0\end{aligned}$$

Rearranging these two equations, we get

$$\mu_k n = w \sin \alpha \quad \text{and} \quad n = w \cos \alpha$$

As in Example 5.10, the normal force is *not* equal to the weight. We eliminate n by dividing the first of these equations by the

5.22 Our sketches for this problem.

(a) The situation

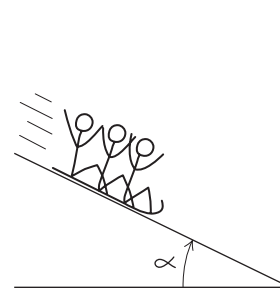

(b) Free-body diagram for toboggan

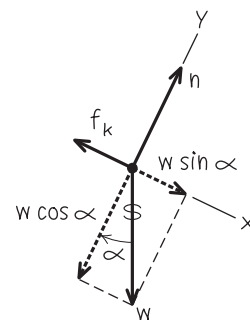

second, with the result

$$\mu_k = \frac{\sin \alpha}{\cos \alpha} = \tan \alpha \quad \text{so} \quad \alpha = \arctan \mu_k$$

EVALUATE: The weight w doesn't appear in this expression. *Any* toboggan, regardless of its weight, slides down an incline with constant speed if the coefficient of kinetic friction equals the tangent of the slope angle of the incline. The arctangent function increases as its argument increases, so it's indeed true that the slope angle α increases as μ_k increases.

Example 5.17 Toboggan ride with friction II

The same toboggan with the same coefficient of friction as in Example 5.16 *accelerates* down a steeper hill. Derive an expression for the acceleration in terms of g , α , μ_k , and w .

SOLUTION

IDENTIFY and SET UP: The toboggan is accelerating, so we must use Newton's second law as given in Eqs. (5.4). Our target variable is the downhill acceleration.

Our sketch and free-body diagram (Fig. 5.23) are almost the same as for Example 5.16. The toboggan's y -component of acceleration a_y is still zero but the x -component a_x is not, so we've drawn the downhill component of weight as a longer vector than the (uphill) friction force.

EXECUTE: It's convenient to express the weight as $w = mg$. Then Newton's second law in component form says

$$\begin{aligned}\sum F_x &= mg \sin \alpha + (-f_k) = ma_x \\ \sum F_y &= n + (-mg \cos \alpha) = 0\end{aligned}$$

5.23 Our sketches for this problem.

(a) The situation

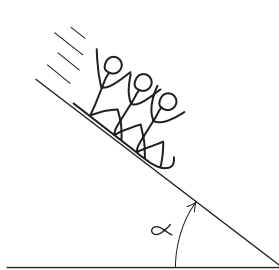

(b) Free-body diagram for toboggan

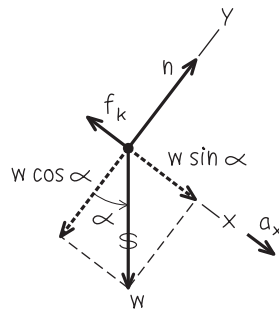

From the second equation and Eq. (5.5) we get an expression for f_k :

$$\begin{aligned}n &= mg \cos \alpha \\ f_k &= \mu_k n = \mu_k mg \cos \alpha\end{aligned}$$

We substitute this into the x -component equation and solve for a_x :

$$\begin{aligned}mg \sin \alpha + (-\mu_k mg \cos \alpha) &= ma_x \\ a_x &= g(\sin \alpha - \mu_k \cos \alpha)\end{aligned}$$

EVALUATE: As for the frictionless toboggan in Example 5.10, the acceleration doesn't depend on the mass m of the toboggan. That's because all of the forces that act on the toboggan (weight, normal force, and kinetic friction force) are proportional to m .

Let's check some special cases. If the hill is vertical ($\alpha = 90^\circ$) so that $\sin \alpha = 1$ and $\cos \alpha = 0$, we have $a_x = g$ (the toboggan falls freely). For a certain value of α the acceleration is zero; this happens if

$$\sin \alpha = \mu_k \cos \alpha \quad \text{and} \quad \mu_k = \tan \alpha$$

This agrees with our result for the constant-velocity toboggan in Example 5.16. If the angle is even smaller, $\mu_k \cos \alpha$ is greater than $\sin \alpha$ and a_x is *negative*; if we give the toboggan an initial downhill push to start it moving, it will slow down and stop. Finally, if the hill is frictionless so that $\mu_k = 0$, we retrieve the result of Example 5.10: $a_x = g \sin \alpha$.

Notice that we started with a simple problem (Example 5.10) and extended it to more and more general situations. The general result we found in this example includes *all* the previous ones as special cases. Don't memorize this result, but do make sure you understand how we obtained it and what it means.

Suppose instead we give the toboggan an initial push *up* the hill. The direction of the kinetic friction force is now reversed, so the acceleration is different from the downhill value. It turns out that the expression for a_x is the same as for downhill motion except that the minus sign becomes plus. Can you show this?

Rolling Friction

It's a lot easier to move a loaded filing cabinet across a horizontal floor using a cart with wheels than to slide it. How much easier? We can define a **coefficient of rolling friction** μ_r , which is the horizontal force needed for constant speed on a flat surface divided by the upward normal force exerted by the surface. Transportation engineers call μ_r the *tractive resistance*. Typical values of μ_r are 0.002 to 0.003 for steel wheels on steel rails and 0.01 to 0.02 for rubber tires on concrete. These values show one reason railroad trains are generally much more fuel efficient than highway trucks.

Fluid Resistance and Terminal Speed

Sticking your hand out the window of a fast-moving car will convince you of the existence of **fluid resistance**, the force that a fluid (a gas or liquid) exerts on a body moving through it. The moving body exerts a force on the fluid to push it out of the way. By Newton's third law, the fluid pushes back on the body with an equal and opposite force.

The *direction* of the fluid resistance force acting on a body is always opposite the direction of the body's velocity relative to the fluid. The *magnitude* of the fluid resistance force usually increases with the speed of the body through the fluid.

5.24 A metal ball falling through a fluid (oil).

(a) Metal ball falling through oil (b) Free-body diagram for ball in oil

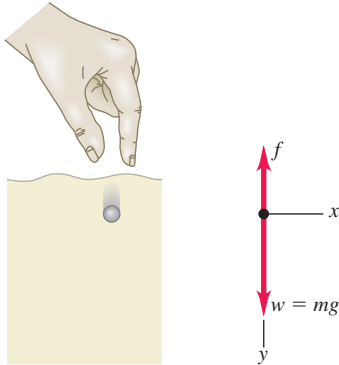

This is very different from the kinetic friction force between two surfaces in contact, which we can usually regard as independent of speed. For small objects moving at very low speeds, the magnitude f of the fluid resistance force is approximately proportional to the body's speed v :

$$f = kv \quad (\text{fluid resistance at low speed}) \quad (5.7)$$

where k is a proportionality constant that depends on the shape and size of the body and the properties of the fluid. Equation (5.7) is appropriate for dust particles falling in air or a ball bearing falling in oil. For larger objects moving through air at the speed of a tossed tennis ball or faster, the resisting force is approximately proportional to v^2 rather than to v . It is then called **air drag** or simply *drag*. Airplanes, falling raindrops, and bicyclists all experience air drag. In this case we replace Eq. (5.7) by

$$f = Dv^2 \quad (\text{fluid resistance at high speed}) \quad (5.8)$$

Because of the v^2 dependence, air drag increases rapidly with increasing speed. The air drag on a typical car is negligible at low speeds but comparable to or greater than rolling resistance at highway speeds. The value of D depends on the shape and size of the body and on the density of the air. You should verify that the units of the constant k in Eq. (5.7) are $\text{N} \cdot \text{s}/\text{m}$ or kg/s , and that the units of the constant D in Eq. (5.8) are $\text{N} \cdot \text{s}^2/\text{m}^2$ or kg/m .

Because of the effects of fluid resistance, an object falling in a fluid does *not* have a constant acceleration. To describe its motion, we can't use the constant-acceleration relationships from Chapter 2; instead, we have to start over using Newton's second law. As an example, suppose you drop a metal ball at the surface of a bucket of oil and let it fall to the bottom (Fig. 5.24a). The fluid resistance force in this situation is given by Eq. (5.7). What are the acceleration, velocity, and position of the metal ball as functions of time?

Figure 5.24b shows the free-body diagram. We take the positive y -direction to be downward and neglect any force associated with buoyancy in the oil. Since the ball is moving downward, its speed v is equal to its y -velocity v_y and the fluid resistance force is in the $-y$ -direction. There are no x -components, so Newton's second law gives

$$\sum F_y = mg + (-kv_y) = ma_y$$

When the ball first starts to move, $v_y = 0$, the resisting force is zero, and the initial acceleration is $a_y = g$. As the speed increases, the resisting force also increases, until finally it is equal in magnitude to the weight. At this time $mg - kv_y = 0$, the acceleration becomes zero, and there is no further increase in speed. The final speed v_t , called the **terminal speed**, is given by $mg - kv_t = 0$, or

$$v_t = \frac{mg}{k} \quad (\text{terminal speed, fluid resistance } f = kv) \quad (5.9)$$

Figure 5.25 shows how the acceleration, velocity, and position vary with time. As time goes by, the acceleration approaches zero and the velocity approaches v_t

Application Pollen and Fluid Resistance

These spiky spheres are pollen grains from the ragweed flower (*Ambrosia psilostachya*) and a common cause of hay fever. Because of their small radius (about $10 \mu\text{m} = 0.01 \text{ mm}$), when they are released into the air the fluid resistance force on them is proportional to their speed. The terminal speed given by Eq. (5.9) is only about 1 cm/s . Hence even a moderate wind can keep pollen grains aloft and carry them substantial distances from their source.

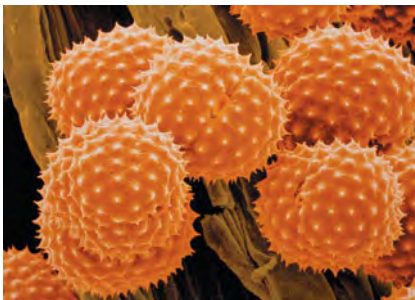

5.25 Graphs of the motion of a body falling without fluid resistance and with fluid resistance proportional to the speed.

Acceleration versus time

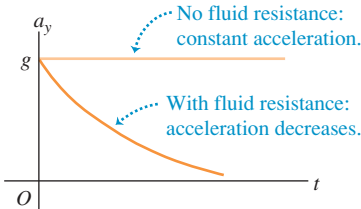

Velocity versus time

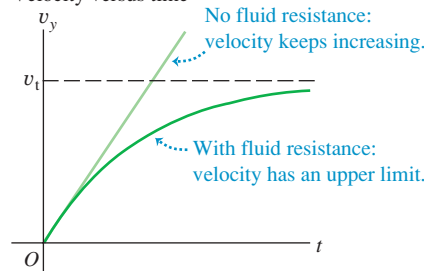

Position versus time

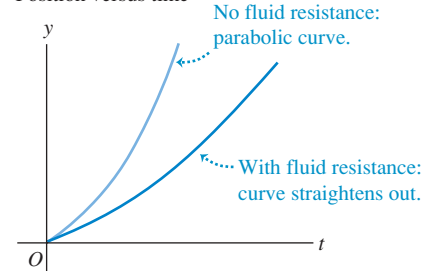

(remember that we chose the positive y -direction to be down). The slope of the graph of y versus t becomes constant as the velocity becomes constant.

To see how the graphs in Fig. 5.25 are derived, we must find the relationship between velocity and time during the interval before the terminal speed is reached. We go back to Newton's second law, which we rewrite using $a_y = dv_y/dt$:

$$m \frac{dv_y}{dt} = mg - kv_y$$

After rearranging terms and replacing mg/k by v_t , we integrate both sides, noting that $v_y = 0$ when $t = 0$:

$$\int_0^v \frac{dv_y}{v_y - v_t} = -\frac{k}{m} \int_0^t dt$$

which integrates to

$$\ln \frac{v_t - v_y}{v_t} = -\frac{k}{m}t \quad \text{or} \quad 1 - \frac{v_y}{v_t} = e^{-(k/m)t}$$

and finally

$$v_y = v_t[1 - e^{-(k/m)t}] \tag{5.10}$$

Note that v_y becomes equal to the terminal speed v_t only in the limit that $t \rightarrow \infty$; the ball cannot attain terminal speed in any finite length of time.

The derivative of v_y gives a_y as a function of time, and the integral of v_y gives y as a function of time. We leave the derivations for you to complete; the results are

$$a_y = ge^{-(k/m)t} \tag{5.11}$$

$$y = v_t \left[t - \frac{m}{k} (1 - e^{-(k/m)t}) \right] \tag{5.12}$$

Now look again at Fig. 5.25, which shows graphs of these three relationships.

In deriving the terminal speed in Eq. (5.9), we assumed that the fluid resistance force is proportional to the speed. For an object falling through the air at high speeds, so that the fluid resistance is equal to Dv^2 as in Eq. (5.8), the terminal speed is reached when Dv^2 equals the weight mg (Fig. 5.26a). You can show that the terminal speed v_t is given by

$$v_t = \sqrt{\frac{mg}{D}} \quad (\text{terminal speed, fluid resistance } f = Dv^2) \tag{5.13}$$

This expression for terminal speed explains why heavy objects in air tend to fall faster than light objects. Two objects with the same physical size but different mass (say, a table-tennis ball and a lead ball with the same radius) have the same value of D but different values of m . The more massive object has a higher terminal speed and falls faster. The same idea explains why a sheet of paper falls faster if you first crumple it into a ball; the mass m is the same, but the smaller size makes D smaller (less air drag for a given speed) and v_t larger. Skydivers use the same principle to control their descent (Fig. 5.26b).

Figure 5.27 shows the trajectories of a baseball with and without air drag, assuming a coefficient $D = 1.3 \times 10^{-3} \text{ kg/m}$ (appropriate for a batted ball at sea level). You can see that both the range of the baseball and the maximum height reached are substantially less than the zero-drag calculation would lead you to believe. Hence the baseball trajectory we calculated in Example 3.8 (Section 3.3) by ignoring air drag is unrealistic. Air drag is an important part of the game of baseball!

5.26 (a) Air drag and terminal speed. (b) By changing the positions of their arms and legs while falling, skydivers can change the value of the constant D in Eq. (5.8) and hence adjust the terminal speed of their fall [Eq. (5.13)].

(a) Free-body diagrams for falling with air drag

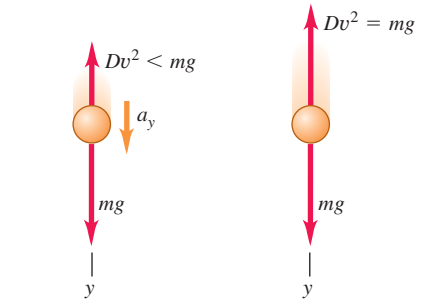

Before terminal speed: Object accelerating, drag force less than weight.

At terminal speed v_t : Object in equilibrium, drag force equals weight.

(b) A skydiver falling at terminal speed



5.27 Computer-generated trajectories of a baseball launched at 50 m/s at 35° above the horizontal. Note that the scales are different on the horizontal and vertical axes.

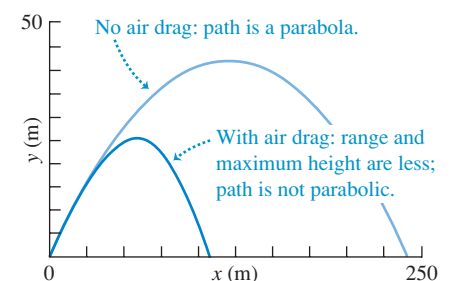

Example 5.18 Terminal speed of a skydiver

For a human body falling through air in a spread-eagle position (Fig. 5.26b), the numerical value of the constant D in Eq. (5.8) is about 0.25 kg/m . Find the terminal speed for a lightweight 50-kg skydiver.

SOLUTION

IDENTIFY and SET UP: This example uses the relationship among terminal speed, mass, and drag coefficient. We use Eq. (5.13) to find the target variable v_t .

EXECUTE: We find for $m = 50 \text{ kg}$:

$$\begin{aligned} v_t &= \sqrt{\frac{mg}{D}} = \sqrt{\frac{(50 \text{ kg})(9.8 \text{ m/s}^2)}{0.25 \text{ kg/m}}} \\ &= 44 \text{ m/s (about 160 km/h, or 99 mi/h)} \end{aligned}$$

EVALUATE: The terminal speed is proportional to the square root of the skydiver's mass. A skydiver with the same drag coefficient D but twice the mass would have a terminal speed $\sqrt{2} = 1.41$ times greater, or 63 m/s . (A more massive skydiver would also have more frontal area and hence a larger drag coefficient, so his terminal speed would be a bit less than 63 m/s .) Even the lightweight skydiver's terminal speed is quite high, so skydives don't last very long. A drop from 2800 m (9200 ft) to the surface at the terminal speed takes only $(2800 \text{ m})/(44 \text{ m/s}) = 64 \text{ s}$.

When the skydiver deploys the parachute, the value of D increases greatly. Hence the terminal speed of the skydiver and parachute decreases dramatically to a much lower value.

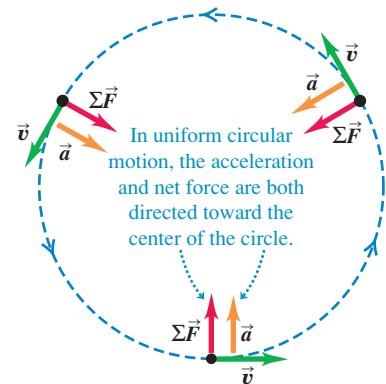
5.28 Net force, acceleration, and velocity in uniform circular motion.**5.29** What happens if the inward radial force suddenly ceases to act on a body in circular motion?

A ball attached to a string whirls in a circle on a frictionless surface.

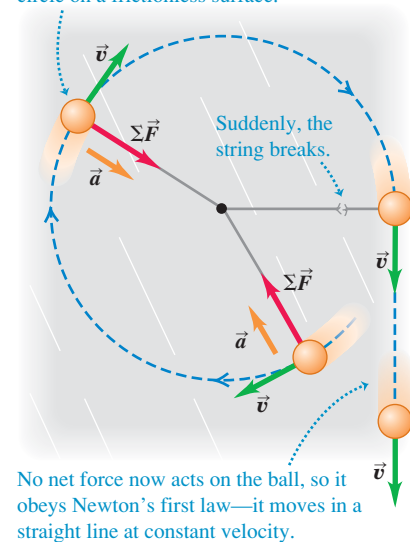

Test Your Understanding of Section 5.3 Consider a box that is placed on different surfaces. (a) In which situation(s) is there *no* friction force acting on the box? (b) In which situation(s) is there a *static* friction force acting on the box? (c) In which situation(s) is there a *kinetic* friction force on the box? (i) The box is at rest on a rough horizontal surface. (ii) The box is at rest on a rough tilted surface. (iii) The box is on the rough-surfaced flat bed of a truck—the truck is moving at a constant velocity on a straight, level road, and the box remains in the same place in the middle of the truck bed. (iv) The box is on the rough-surfaced flat bed of a truck—the truck is speeding up on a straight, level road, and the box remains in the same place in the middle of the truck bed. (v) The box is on the rough-surfaced flat bed of a truck—the truck is climbing a hill, and the box is sliding toward the back of the truck.

5.4 Dynamics of Circular Motion

We talked about uniform circular motion in Section 3.4. We showed that when a particle moves in a circular path with constant speed, the particle's acceleration is always directed toward the center of the circle (perpendicular to the instantaneous velocity). The magnitude a_{rad} of the acceleration is constant and is given in terms of the speed v and the radius R of the circle by

$$a_{\text{rad}} = \frac{v^2}{R} \quad (\text{uniform circular motion}) \quad (5.14)$$

The subscript “rad” is a reminder that at each point the acceleration is radially inward toward the center of the circle, perpendicular to the instantaneous velocity. We explained in Section 3.4 why this acceleration is often called *centripetal acceleration*.

We can also express the centripetal acceleration a_{rad} in terms of the *period* T , the time for one revolution:

$$T = \frac{2\pi R}{v} \quad (5.15)$$

In terms of the period, a_{rad} is

$$a_{\text{rad}} = \frac{4\pi^2 R}{T^2} \quad (\text{uniform circular motion}) \quad (5.16)$$

Uniform circular motion, like all other motion of a particle, is governed by Newton's second law. To make the particle accelerate toward the center of the circle, the net force $\Sigma \vec{F}$ on the particle must always be directed toward the center (Fig. 5.28). The magnitude of the acceleration is constant, so the magnitude F_{net} of the net force must also be constant. If the inward net force stops acting, the particle flies off in a straight line tangent to the circle (Fig. 5.29).

The magnitude of the radial acceleration is given by $a_{\text{rad}} = v^2/R$, so the magnitude F_{net} of the net force on a particle with mass m in uniform circular motion must be

$$F_{\text{net}} = ma_{\text{rad}} = m \frac{v^2}{R} \quad (\text{uniform circular motion}) \quad (5.17)$$

Uniform circular motion can result from *any* combination of forces, just so the net force $\Sigma \vec{F}$ is always directed toward the center of the circle and has a constant magnitude. Note that the body need not move around a complete circle: Equation (5.17) is valid for *any* path that can be regarded as part of a circular arc.

CAUTION Avoid using “centrifugal force” Figure 5.30 shows both a correct free-body diagram for uniform circular motion (Fig. 5.30a) and a common *incorrect* diagram (Fig. 5.30b). Figure 5.30b is incorrect because it includes an extra outward force of magnitude $m(v^2/R)$ to “keep the body out there” or to “keep it in equilibrium.” There are three reasons not to include such an outward force, usually called *centrifugal force* (“centrifugal” means “fleeing from the center”). First, the body does *not* “stay out there”: It is in constant motion around its circular path. Because its velocity is constantly changing in direction, the body accelerates and is *not* in equilibrium. Second, if there *were* an additional outward force that balanced the inward force, the net force would be zero and the body would move in a straight line, not a circle (Fig. 5.29). And third, the quantity $m(v^2/R)$ is *not* a force; it corresponds to the $m\vec{a}$ side of $\Sigma \vec{F} = m\vec{a}$ and does not appear in $\Sigma \vec{F}$ (Fig. 5.30a). It’s true that when you ride in a car that goes around a circular path, you tend to slide to the outside of the turn as though there was a “centrifugal force.” But we saw in Section 4.2 that what really happens is that you tend to keep moving in a straight line, and the outer side of the car “runs into” you as the car turns (Fig. 4.11c). *In an inertial frame of reference there is no such thing as “centrifugal force.”* We won’t mention this term again, and we strongly advise you to avoid using it as well. **|**

5.30 (a) Correct and (b) incorrect free-body diagrams for a body in uniform circular motion.

(a) Correct free-body diagram

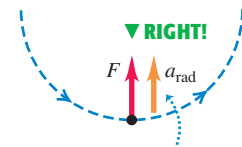

If you include the acceleration, draw it to one side of the body to show that it’s not a force.

(b) Incorrect free-body diagram

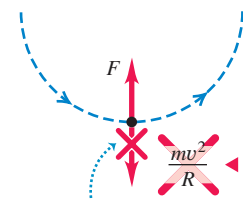

The quantity mv^2/R is *not* a force—it doesn’t belong in a free-body diagram.

Example 5.19 Force in uniform circular motion

A sled with a mass of 25.0 kg rests on a horizontal sheet of essentially frictionless ice. It is attached by a 5.00-m rope to a post set in the ice. Once given a push, the sled revolves uniformly in a circle around the post (Fig. 5.31a). If the sled makes five complete revolutions every minute, find the force F exerted on it by the rope.

SOLUTION

IDENTIFY and SET UP: The sled is in uniform circular motion, so it has a constant radial acceleration. We’ll apply Newton’s second law to the sled to find the magnitude F of the force exerted by the rope (our target variable).

5.31 (a) The situation. (b) Our free-body diagram.

(a) A sled in uniform circular motion (b) Free-body diagram for sled

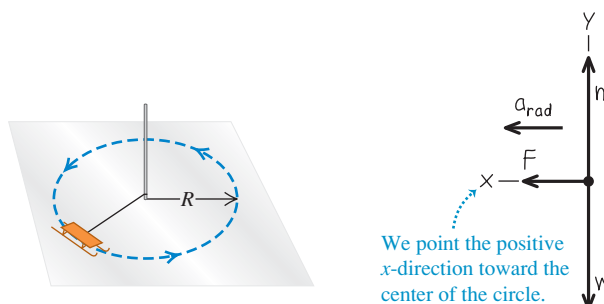

Figure 5.31b shows our free-body diagram for the sled. The acceleration has only an x -component; this is toward the center of the circle, so we denote it as a_{rad} . The acceleration isn’t given, so we’ll need to determine its value using either Eq. (5.14) or Eq. (5.16).

EXECUTE: The force F appears in Newton’s second law for the x -direction:

$$\Sigma F_x = F = ma_{\text{rad}}$$

We can find the centripetal acceleration a_{rad} using Eq. (5.16). The sled moves in a circle of radius $R = 5.00$ m with a period $T = (60.0 \text{ s})/(5 \text{ rev}) = 12.0$ s, so

$$a_{\text{rad}} = \frac{4\pi^2 R}{T^2} = \frac{4\pi^2(5.00 \text{ m})}{(12.0 \text{ s})^2} = 1.37 \text{ m/s}^2$$

The magnitude F of the force exerted by the rope is then

$$\begin{aligned} F &= ma_{\text{rad}} = (25.0 \text{ kg})(1.37 \text{ m/s}^2) \\ &= 34.3 \text{ kg} \cdot \text{m/s}^2 = 34.3 \text{ N} \end{aligned}$$

EVALUATE: You can check our value for a_{rad} by first finding the speed using Eq. (5.15), $v = 2\pi R/T$, and then using $a_{\text{rad}} = v^2/R$ from Eq. (5.14). Do you get the same result?

A greater force would be needed if the sled moved around the circle at a higher speed v . In fact, if v were doubled while R remained the same, F would be four times greater. Can you show this? How would F change if v remained the same but the radius R were doubled?

Example 5.20 A conical pendulum

An inventor designs a pendulum clock using a bob with mass m at the end of a thin wire of length L . Instead of swinging back and forth, the bob is to move in a horizontal circle with constant speed v , with the wire making a fixed angle β with the vertical direction (Fig. 5.32a). This is called a *conical pendulum* because the suspending wire traces out a cone. Find the tension F in the wire and the period T (the time for one revolution of the bob).

SOLUTION

IDENTIFY and SET UP: To find our target variables, the tension F and period T , we need two equations. These will be the horizontal and vertical components of Newton's second law applied to the bob. We'll find the radial acceleration of the bob using one of the circular motion equations.

Figure 5.32b shows our free-body diagram and coordinate system for the bob at a particular instant. There are just two forces on the bob: the weight mg and the tension F in the wire. Note that the

5.32 (a) The situation. (b) Our free-body diagram.

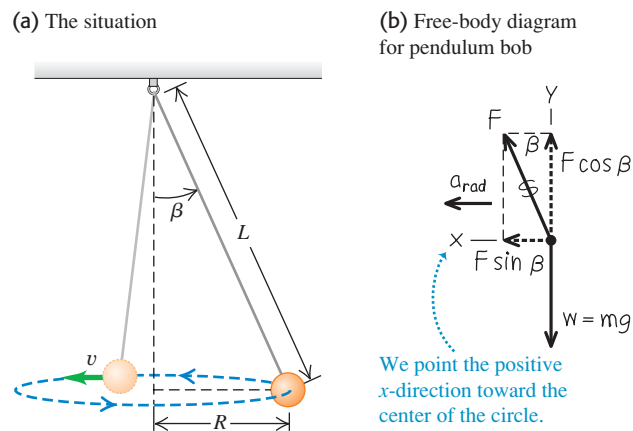

center of the circular path is in the same horizontal plane as the bob, *not* at the top end of the wire. The horizontal component of tension is the force that produces the radial acceleration a_{rad} .

EXECUTE: The bob has zero vertical acceleration; the horizontal acceleration is toward the center of the circle, which is why we use the symbol a_{rad} . Newton's second law says

$$\begin{aligned}\sum F_x &= F \sin \beta = ma_{\text{rad}} \\ \sum F_y &= F \cos \beta + (-mg) = 0\end{aligned}$$

These are two equations for the two unknowns F and β . The equation for $\sum F_y$ gives $F = mg/\cos \beta$; that's our target expression for F in terms of β . Substituting this result into the equation for $\sum F_x$ and using $\sin \beta/\cos \beta = \tan \beta$, we find

$$a_{\text{rad}} = g \tan \beta$$

To relate β to the period T , we use Eq. (5.16) for a_{rad} , solve for T , and insert $a_{\text{rad}} = g \tan \beta$:

$$\begin{aligned}a_{\text{rad}} &= \frac{4\pi^2 R}{T^2} \quad \text{so} \quad T^2 = \frac{4\pi^2 R}{a_{\text{rad}}} \\ T &= 2\pi \sqrt{\frac{R}{g \tan \beta}}\end{aligned}$$

Figure 5.32a shows that $R = L \sin \beta$. We substitute this and use $\sin \beta/\tan \beta = \cos \beta$:

$$T = 2\pi \sqrt{\frac{L \cos \beta}{g}}$$

EVALUATE: For a given length L , as the angle β increases, $\cos \beta$ decreases, the period T becomes smaller, and the tension $F = mg/\cos \beta$ increases. The angle can never be 90° , however; this would require that $T = 0$, $F = \infty$, and $v = \infty$. A conical pendulum would not make a very good clock because the period depends on the angle β in such a direct way.

Example 5.21 Rounding a flat curve

The sports car in Example 3.11 (Section 3.4) is rounding a flat, unbanked curve with radius R (Fig. 5.33a). If the coefficient of static friction between tires and road is μ_s , what is the maximum speed v_{max} at which the driver can take the curve without sliding?

SOLUTION

IDENTIFY and SET UP: The car's acceleration as it rounds the curve has magnitude $a_{\text{rad}} = v^2/R$. Hence the maximum speed v_{max} (our target variable) corresponds to the maximum acceleration a_{rad} and to the maximum horizontal force on the car toward the center of its circular path. The only horizontal force acting on the car is the friction force exerted by the road. So to solve this problem we'll need Newton's second law, the equations of uniform circular motion, and our knowledge of the friction force from Section 5.3.

The free-body diagram in Fig. 5.33b includes the car's weight $w = mg$ and the two forces exerted by the road: the normal force n and the horizontal friction force f . The friction force must point toward the center of the circular path in order to cause the radial acceleration. The car doesn't slide toward or away from the center

of the circle, so the friction force is *static* friction, with a maximum magnitude $f_{\text{max}} = \mu_s n$ [see Eq. (5.6)].

5.33 (a) The situation. (b) Our free-body diagram.

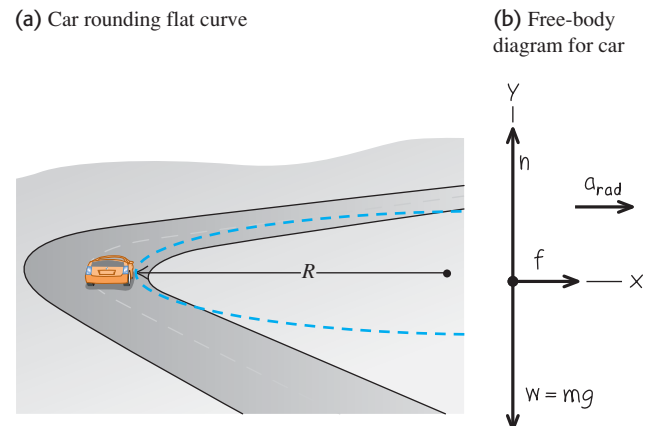

EXECUTE: The acceleration toward the center of the circular path is $a_{\text{rad}} = v^2/R$. There is no vertical acceleration. Thus we have

$$\begin{aligned}\sum F_x &= f = ma_{\text{rad}} = m \frac{v^2}{R} \\ \sum F_y &= n + (-mg) = 0\end{aligned}$$

The second equation shows that $n = mg$. The first equation shows that the friction force *needed* to keep the car moving in its circular path increases with the car's speed. But the maximum friction force *available* is $f_{\text{max}} = \mu_s n = \mu_s mg$, and this determines the car's maximum speed. Substituting $\mu_s mg$ for f and v_{max} for v in the first equation, we find

$$\mu_s mg = m \frac{v_{\text{max}}^2}{R} \quad \text{so} \quad v_{\text{max}} = \sqrt{\mu_s g R}$$

As an example, if $\mu_s = 0.96$ and $R = 230$ m, we have

$$v_{\text{max}} = \sqrt{(0.96)(9.8 \text{ m/s}^2)(230 \text{ m})} = 47 \text{ m/s}$$

or about 170 km/h (100 mi/h). This is the maximum speed for this radius.

EVALUATE: If the car's speed is slower than $v_{\text{max}} = \sqrt{\mu_s g R}$, the required friction force is less than the maximum value $f_{\text{max}} = \mu_s mg$, and the car can easily make the curve. If we try to take the curve going *faster* than v_{max} , we will skid. We could still go in a circle without skidding at this higher speed, but the radius would have to be larger.

The maximum centripetal acceleration (called the "lateral acceleration" in Example 3.11) is equal to $\mu_s g$. That's why it's best to take curves at less than the posted speed limit if the road is wet or icy, either of which can reduce the value of μ_s and hence $\mu_s g$.

Example 5.22 Rounding a banked curve

For a car traveling at a certain speed, it is possible to bank a curve at just the right angle so that no friction at all is needed to maintain the car's turning radius. Then a car can safely round the curve even on wet ice. (Bobsled racing depends on this same idea.) Your engineering firm plans to rebuild the curve in Example 5.21 so that a car moving at a chosen speed v can safely make the turn even with no friction (Fig. 5.34a). At what angle β should the curve be banked?

SOLUTION

IDENTIFY and SET UP: With no friction, the only forces acting on the car are its weight and the normal force. Because the road is banked, the normal force (which acts perpendicular to the road surface) has a horizontal component. This component causes the car's horizontal acceleration toward the center of the car's circular path. We'll use Newton's second law to find the target variable β .

Our free-body diagram (Fig. 5.34b) is very similar to the diagram for the conical pendulum in Example 5.20 (Fig. 5.32b). The normal force acting on the car plays the role of the tension force exerted by the wire on the pendulum bob.

EXECUTE: The normal force \vec{n} is perpendicular to the roadway and is at an angle β with the vertical (Fig. 5.34b). Thus it has a vertical component $n \cos \beta$ and a horizontal component $n \sin \beta$.

The acceleration in the x -direction is the centripetal acceleration $a_{\text{rad}} = v^2/R$; there is no acceleration in the y -direction. Thus the equations of Newton's second law are

$$\begin{aligned}\sum F_x &= n \sin \beta = ma_{\text{rad}} \\ \sum F_y &= n \cos \beta + (-mg) = 0\end{aligned}$$

From the $\sum F_y$ equation, $n = mg/\cos \beta$. Substituting this into the $\sum F_x$ equation and using $a_{\text{rad}} = v^2/R$, we get an expression for the bank angle:

$$\tan \beta = \frac{a_{\text{rad}}}{g} = \frac{v^2}{gR} \quad \text{so} \quad \beta = \arctan \frac{v^2}{gR}$$

EVALUATE: The bank angle depends on both the speed and the radius. For a given radius, no one angle is correct for all speeds. In the design of highways and railroads, curves are often banked for the average speed of the traffic over them. If $R = 230$ m and $v = 25$ m/s (equal to a highway speed of 88 km/h, or 55 mi/h), then

$$\beta = \arctan \frac{(25 \text{ m/s})^2}{(9.8 \text{ m/s}^2)(230 \text{ m})} = 15^\circ$$

This is within the range of banking angles actually used in highways.

5.34 (a) The situation. (b) Our free-body diagram.

(a) Car rounding banked curve

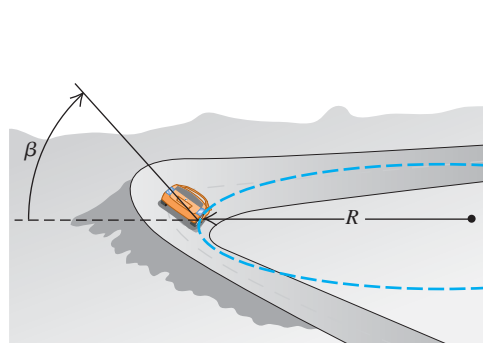

(b) Free-body diagram for car

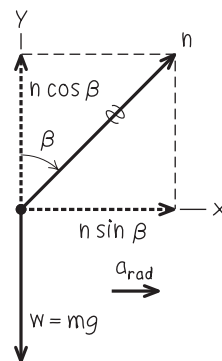

5.35 An airplane banks to one side in order to turn in that direction. The vertical component of the lift force \vec{L} balances the force of gravity; the horizontal component of \vec{L} causes the acceleration v^2/R .

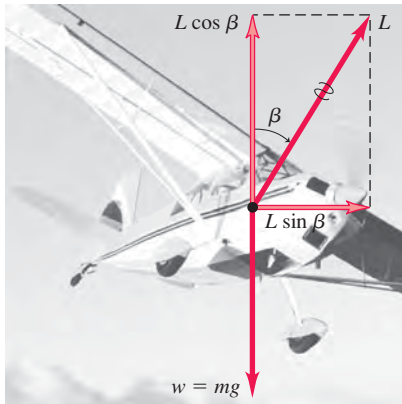

Banked Curves and the Flight of Airplanes

The results of Example 5.22 also apply to an airplane when it makes a turn in level flight (Fig. 5.35). When an airplane is flying in a straight line at a constant speed and at a steady altitude, the airplane's weight is exactly balanced by the lift force \vec{L} exerted by the air. (The upward lift force that the air exerts on the wings is a reaction to the downward push the wings exert on the air as they move through it.) To make the airplane turn, the pilot banks the airplane to one side so that the lift force has a horizontal component as Fig. 5.35 shows. (The pilot also changes the angle at which the wings "bite" into the air so that the vertical component of lift continues to balance the weight.) The bank angle is related to the airplane's speed v and the radius R of the turn by the same expression as in Example 5.22: $\tan \beta = v^2/gR$. For an airplane to make a tight turn (small R) at high speed (large v), $\tan \beta$ must be large and the required bank angle β must approach 90° .

We can also apply the results of Example 5.22 to the *pilot* of an airplane. The free-body diagram for the pilot of the airplane is exactly as shown in Fig. 5.34b; the normal force $n = mg/\cos \beta$ is exerted on the pilot by the seat. As in Example 5.9, n is equal to the apparent weight of the pilot, which is greater than the pilot's true weight mg . In a tight turn with a large bank angle β , the pilot's apparent weight can be tremendous: $n = 5.8mg$ at $\beta = 80^\circ$ and $n = 9.6mg$ at $\beta = 84^\circ$. Pilots black out in such tight turns because the apparent weight of their blood increases by the same factor, and the human heart isn't strong enough to pump such apparently "heavy" blood to the brain.

MasteringPHYSICS

ActivPhysics 4.2: Circular Motion Problem Solving

ActivPhysics 4.3: Cart Goes over Circular Path

ActivPhysics 4.4: Ball Swings on a String

ActivPhysics 4.5: Car Circles a Track

Motion in a Vertical Circle

In Examples 5.19, 5.20, 5.21, and 5.22 the body moved in a horizontal circle. Motion in a *vertical* circle is no different in principle, but the weight of the body has to be treated carefully. The following example shows what we mean.

Example 5.23 Uniform circular motion in a vertical circle

A passenger on a carnival Ferris wheel moves in a vertical circle of radius R with constant speed v . The seat remains upright during the motion. Find expressions for the force the seat exerts on the passenger at the top of the circle and at the bottom.

SOLUTION

IDENTIFY and SET UP: The target variables are n_T , the upward normal force the seat applies to the passenger at the top of the circle, and n_B , the normal force at the bottom. We'll find these using Newton's second law and the uniform circular motion equations.

Figure 5.36a shows the passenger's velocity and acceleration at the two positions. The acceleration always points toward the center of the circle—downward at the top of the circle and upward at the bottom of the circle. At each position the only forces acting are vertical: the upward normal force and the downward force of gravity. Hence we need only the vertical component of Newton's second law. Figures 5.36b and 5.36c show free-body diagrams for the two positions. We take the positive y -direction as upward in both cases (that is, *opposite* the direction of the acceleration at the top of the circle).

EXECUTE: At the top the acceleration has magnitude v^2/R , but its vertical component is negative because its direction is downward.

Hence $a_y = -v^2/R$ and Newton's second law tells us that

$$\begin{aligned} \text{Top: } \quad \sum F_y &= n_T + (-mg) = -m \frac{v^2}{R} \quad \text{or} \\ n_T &= mg \left(1 - \frac{v^2}{gR} \right) \end{aligned}$$

5.36 Our sketches for this problem.

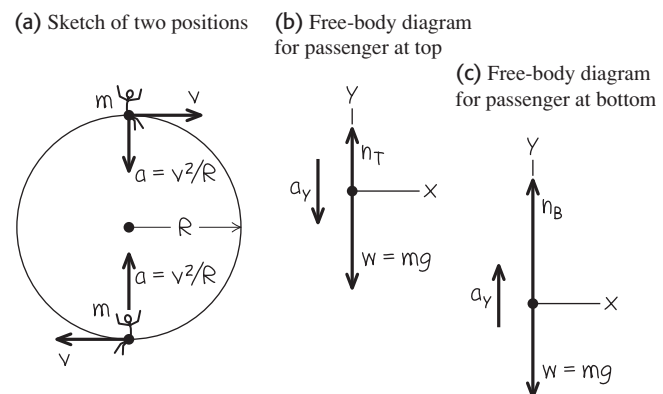

At the bottom the acceleration is upward, so $a_y = +v^2/R$ and Newton's second law says

$$\text{Bottom: } \sum F_y = n_B + (-mg) = +m \frac{v^2}{R} \quad \text{or}$$

$$n_B = mg \left(1 + \frac{v^2}{gR} \right)$$

EVALUATE: Our result for n_T tells us that at the top of the Ferris wheel, the upward force the seat applies to the passenger is *smaller*

in magnitude than the passenger's weight $w = mg$. If the ride goes fast enough that $g - v^2/R$ becomes zero, the seat applies *no* force, and the passenger is about to become airborne. If v becomes still larger, n_T becomes negative; this means that a *downward* force (such as from a seat belt) is needed to keep the passenger in the seat. By contrast, the normal force n_B at the bottom is always *greater* than the passenger's weight. You feel the seat pushing up on you more firmly than when you are at rest. You can see that n_T and n_B are the values of the passenger's *apparent weight* at the top and bottom of the circle (see Section 5.2).

When we tie a string to an object and whirl it in a vertical circle, the analysis in Example 5.23 isn't directly applicable. The reason is that v is *not* constant in this case; except at the top and bottom of the circle, the net force (and hence the acceleration) does *not* point toward the center of the circle (Fig. 5.37). So both $\sum \vec{F}$ and \vec{a} have a component tangent to the circle, which means that the speed changes. Hence this is a case of *nonuniform* circular motion (see Section 3.4). Even worse, we can't use the constant-acceleration formulas to relate the speeds at various points because *neither* the magnitude nor the direction of the acceleration is constant. The speed relationships we need are best obtained by using the concept of energy. We'll consider such problems in Chapter 7.

Test Your Understanding of Section 5.4 Satellites are held in orbit by the force of our planet's gravitational attraction. A satellite in a small-radius orbit moves at a higher speed than a satellite in an orbit of large radius. Based on this information, what you can conclude about the earth's gravitational attraction for the satellite? (i) It increases with increasing distance from the earth. (ii) It is the same at all distances from the earth. (iii) It decreases with increasing distance from the earth. (iv) This information by itself isn't enough to answer the question. MP

5.37 A ball moving in a vertical circle.

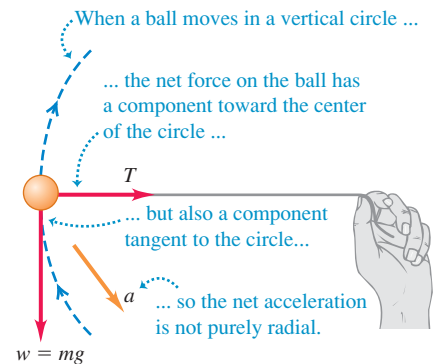

5.5 The Fundamental Forces of Nature

We have discussed several kinds of forces—including weight, tension, friction, fluid resistance, and the normal force—and we will encounter others as we continue our study of physics. But just how many kinds of forces are there? Our current understanding is that all forces are expressions of just four distinct classes of *fundamental* forces, or interactions between particles (Fig. 5.38). Two are familiar in everyday experience. The other two involve interactions between subatomic particles that we cannot observe with the unaided senses.

Gravitational interactions include the familiar force of your *weight*, which results from the earth's gravitational attraction acting on you. The mutual gravitational attraction of various parts of the earth for each other holds our planet together (Fig. 5.38a). Newton recognized that the sun's gravitational attraction for the earth keeps the earth in its nearly circular orbit around the sun. In Chapter 13 we will study gravitational interactions in greater detail, and we will analyze their vital role in the motions of planets and satellites.

The second familiar class of forces, **electromagnetic interactions**, includes electric and magnetic forces. If you run a comb through your hair, the comb ends up with an electric charge; you can use the electric force exerted by this charge to pick up bits of paper. All atoms contain positive and negative electric charge, so atoms and molecules can exert electric forces on one another (Fig. 5.38b). Contact forces, including the normal force, friction, and fluid resistance, are the combination of all such forces exerted on the atoms of a body by atoms in its surroundings. *Magnetic* forces, such as those between magnets or between a magnet and a piece of iron, are actually the result of electric charges in motion. For example, an electromagnet causes magnetic interactions because electric

5.38 Examples of the fundamental interactions in nature. (a) The moon and the earth are held together and held in orbit by gravitational forces. (b) This molecule of bacterial plasmid DNA is held together by electromagnetic forces between its atoms. (c) The sun shines because in its core, strong forces between nuclear particles cause the release of energy. (d) When a massive star explodes into a supernova, a flood of energy is released by weak interactions between the star's nuclear particles.

(a) Gravitational forces hold planets together.



(b) Electromagnetic forces hold molecules together.

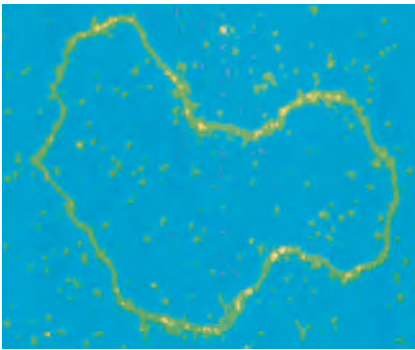

(c) Strong forces release energy to power the sun.



(d) Weak forces play a role in exploding stars.

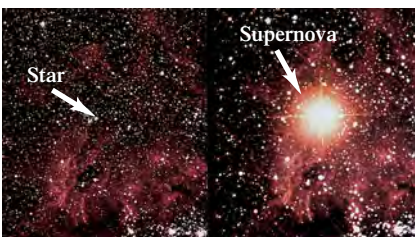

charges move through its wires. We will study electromagnetic interactions in detail in the second half of this book.

On the atomic or molecular scale, gravitational forces play no role because electric forces are enormously stronger: The electrical repulsion between two protons is stronger than their gravitational attraction by a factor of about 10^{35} . But in bodies of astronomical size, positive and negative charges are usually present in nearly equal amounts, and the resulting electrical interactions nearly cancel out. Gravitational interactions are thus the dominant influence in the motion of planets and in the internal structure of stars.

The other two classes of interactions are less familiar. One, the **strong interaction**, is responsible for holding the nucleus of an atom together. Nuclei contain electrically neutral neutrons and positively charged protons. The electric force between charged protons tries to push them apart; the strong attractive force between nuclear particles counteracts this repulsion and makes the nucleus stable. In this context the strong interaction is also called the *strong nuclear force*. It has much shorter range than electrical interactions, but within its range it is much stronger. The strong interaction plays a key role in thermonuclear reactions that take place at the sun's core and generate the sun's heat and light (Fig. 5.38c).

Finally, there is the **weak interaction**. Its range is so short that it plays a role only on the scale of the nucleus or smaller. The weak interaction is responsible for a common form of radioactivity called beta decay, in which a neutron in a radioactive nucleus is transformed into a proton while ejecting an electron and a nearly massless particle called an antineutrino. The weak interaction between the antineutrino and ordinary matter is so feeble that an antineutrino could easily penetrate a wall of lead a million kilometers thick! Yet when a giant star undergoes a cataclysmic explosion called a supernova, most of the energy is released by way of the weak interaction (Fig. 5.38d).

In the 1960s physicists developed a theory that described the electromagnetic and weak interactions as aspects of a single *electroweak* interaction. This theory has passed every experimental test to which it has been put. Encouraged by this success, physicists have made similar attempts to describe the strong, electromagnetic, and weak interactions in terms of a single *grand unified theory* (GUT), and have taken steps toward a possible unification of all interactions into a *theory of everything* (TOE). Such theories are still speculative, and there are many unanswered questions in this very active field of current research.

CHAPTER 5 SUMMARY

Using Newton's first law: When a body is in equilibrium in an inertial frame of reference—that is, either at rest or moving with constant velocity—the vector sum of forces acting on it must be zero (Newton's first law). Free-body diagrams are essential in identifying the forces that act on the body being considered.

Newton's third law (action and reaction) is also frequently needed in equilibrium problems. The two forces in an action–reaction pair *never* act on the same body. (See Examples 5.1–5.5.)

The normal force exerted on a body by a surface is *not* always equal to the body's weight. (See Example 5.3.)

$$\sum \vec{F} = \mathbf{0} \quad (\text{vector form}) \quad (5.1)$$

$$\begin{aligned} \sum F_x &= 0 \\ \sum F_y &= 0 \end{aligned} \quad (\text{component form}) \quad (5.2)$$

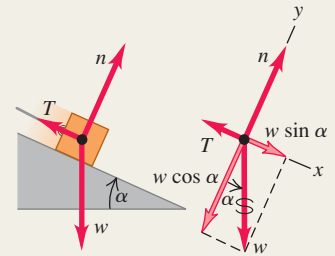

Using Newton's second law: If the vector sum of forces on a body is *not* zero, the body accelerates. The acceleration is related to the net force by Newton's second law.

Just as for equilibrium problems, free-body diagrams are essential for solving problems involving Newton's second law, and the normal force exerted on a body is not always equal to its weight. (See Examples 5.6–5.12.)

Vector form:

$$\sum \vec{F} = m\vec{a} \quad (5.3)$$

Component form:

$$\sum F_x = ma_x \quad \sum F_y = ma_y \quad (5.4)$$

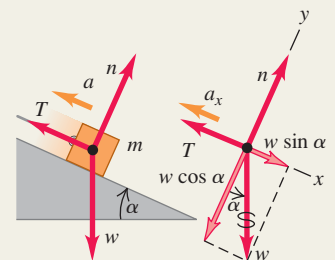

Friction and fluid resistance: The contact force between two bodies can always be represented in terms of a normal force \vec{n} perpendicular to the surface of contact and a friction force \vec{f} parallel to the surface.

When a body is sliding over the surface, the friction force is called *kinetic* friction. Its magnitude f_k is approximately equal to the normal force magnitude n multiplied by the coefficient of kinetic friction μ_k .

When a body is *not* moving relative to a surface, the friction force is called *static* friction. The *maximum* possible static friction force is approximately equal to the magnitude n of the normal force multiplied by the coefficient of static friction μ_s . The *actual* static friction force may be anything from zero to this maximum value, depending on the situation. Usually μ_s is greater than μ_k for a given pair of surfaces in contact. (See Examples 5.13–5.17.)

Rolling friction is similar to kinetic friction, but the force of fluid resistance depends on the speed of an object through a fluid. (See Example 5.18.)

Magnitude of kinetic friction force:

$$f_k = \mu_k n \quad (5.5)$$

Magnitude of static friction force:

$$f_s \leq \mu_s n \quad (5.6)$$

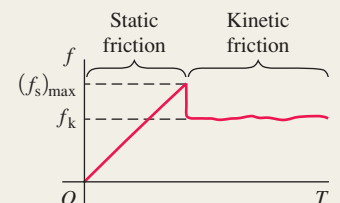

Forces in circular motion: In uniform circular motion, the acceleration vector is directed toward the center of the circle. The motion is governed by Newton's second law, $\sum \vec{F} = m\vec{a}$. (See Examples 5.19–5.23.)

Acceleration in uniform circular motion:

$$a_{\text{rad}} = \frac{v^2}{R} = \frac{4\pi^2 R}{T^2} \quad (5.14), (5.16)$$

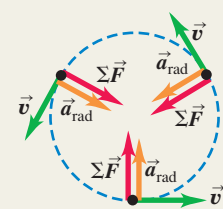

BRIDGING PROBLEM

In a Rotating Cone

A small block with mass m is placed inside an inverted cone that is rotating about a vertical axis such that the time for one revolution of the cone is T (Fig. 5.39). The walls of the cone make an angle β with the horizontal. The coefficient of static friction between the block and the cone is μ_s . If the block is to remain at a constant height h above the apex of the cone, what are (a) the maximum value of T and (b) the minimum value of T ? (That is, find expressions for T_{\max} and T_{\min} in terms of β and h .)

SOLUTION GUIDE

See MasteringPhysics[®] Study Area for a Video Tutor solution.



IDENTIFY and SET UP

1. Although we want the block to not slide up or down on the inside of the cone, this is *not* an equilibrium problem. The block rotates with the cone and is in uniform circular motion, so it has an acceleration directed toward the center of its circular path.
2. Identify the forces on the block. What is the direction of the friction force when the cone is rotating as slowly as possible, so T has its maximum value T_{\max} ? What is the direction of the friction force when the cone is rotating as rapidly as possible, so T has its minimum value T_{\min} ? In these situations does the static friction force have its *maximum* magnitude? Why or why not?
3. Draw a free-body diagram for the block when the cone is rotating with $T = T_{\max}$ and a free-body diagram when the cone is rotating with $T = T_{\min}$. Choose coordinate axes, and remember that it's usually easiest to choose one of the axes to be in the direction of the acceleration.
4. What is the radius of the circular path that the block follows? Express this in terms of β and h .
5. Make a list of the unknown quantities, and decide which of these are the target variables.

5.39 A block inside a spinning cone.

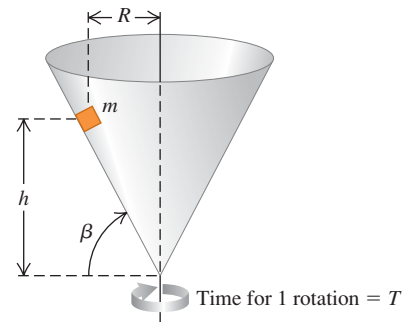

EXECUTE

6. Write Newton's second law in component form for the case in which the cone is rotating with $T = T_{\max}$. Write the acceleration in terms of T_{\max} , β , and h , and write the static friction force in terms of the normal force n .
7. Solve these equations for the target variable T_{\max} .
8. Repeat steps 6 and 7 for the case in which the cone is rotating with $T = T_{\min}$, and solve for the target variable T_{\min} .

EVALUATE

9. You'll end up with some fairly complicated expressions for T_{\max} and T_{\min} , so check them over carefully. Do they have the correct units? Is the minimum time T_{\min} less than the maximum time T_{\max} , as it must be?
10. What do your expressions for T_{\max} and T_{\min} become if $\mu_s = 0$? Check your results by comparing with Example 5.22 in Section 5.4.

Problems

For instructor-assigned homework, go to www.masteringphysics.com



•, ••, •••: Problems of increasing difficulty. CP: Cumulative problems incorporating material from earlier chapters. CALC: Problems requiring calculus. BIO: Biosciences problems.

DISCUSSION QUESTIONS

- Q5.1** A man sits in a seat that is suspended from a rope. The rope passes over a pulley suspended from the ceiling, and the man holds the other end of the rope in his hands. What is the tension in the rope, and what force does the seat exert on the man? Draw a free-body force diagram for the man.
- Q5.2** "In general, the normal force is not equal to the weight." Give an example where these two forces are equal in magnitude, and at least two examples where they are not.
- Q5.3** A clothesline hangs between two poles. No matter how tightly the line is stretched, it always sags a little at the center. Explain why.
- Q5.4** A car is driven up a steep hill at constant speed. Discuss all the forces acting on the car. What pushes it up the hill?
- Q5.5** For medical reasons it is important for astronauts in outer space to determine their body mass at regular intervals. Devise a scheme for measuring body mass in an apparently weightless environment.

- Q5.6** To push a box up a ramp, is the force required smaller if you push horizontally or if you push parallel to the ramp? Why?
- Q5.7** A woman in an elevator lets go of her briefcase but it does not fall to the floor. How is the elevator moving?
- Q5.8** You can classify scales for weighing objects as those that use springs and those that use standard masses to balance unknown masses. Which group would be more accurate when used in an accelerating spaceship? When used on the moon?
- Q5.9** When you tighten a nut on a bolt, how are you increasing the frictional force? How does a lock washer work?
- Q5.10** A block rests on an inclined plane with enough friction to prevent it from sliding down. To start the block moving, is it easier to push it up the plane or down the plane? Why?
- Q5.11** A crate of books rests on a level floor. To move it along the floor at a constant velocity, why do you exert a smaller force if you pull it at an angle θ above the horizontal than if you push it at the same angle below the horizontal?

Q5.12 In a world without friction, which of the following activities could you do (or not do)? Explain your reasoning. (a) drive around an unbanked highway curve; (b) jump into the air; (c) start walking on a horizontal sidewalk; (d) climb a vertical ladder; (e) change lanes on the freeway.

Q5.13 Walking on horizontal slippery ice can be much more tiring than walking on ordinary pavement. Why?

Q5.14 When you stand with bare feet in a wet bathtub, the grip feels fairly secure, and yet a catastrophic slip is quite possible. Explain this in terms of the two coefficients of friction.

Q5.15 You are pushing a large crate from the back of a freight elevator to the front as the elevator is moving to the next floor. In which situation is the force you must apply to move the crate the smallest and in which is it the largest: when the elevator is accelerating upward, when it is accelerating downward, or when it is traveling at constant speed? Explain.

Q5.16 The moon is accelerating toward the earth. Why isn't it getting closer to us?

Q5.17 An automotive magazine calls decreasing-radius curves "the bane of the Sunday driver." Explain.

Q5.18 You often hear people say that "friction always opposes motion." Give at least one example where (a) static friction *causes* motion, and (b) kinetic friction *causes* motion.

Q5.19 If there is a net force on a particle in uniform circular motion, why doesn't the particle's speed change?

Q5.20 A curve in a road has the banking angle calculated and posted for 80 km/h. However, the road is covered with ice so you cautiously plan to drive slower than this limit. What may happen to your car? Why?

Q5.21 You swing a ball on the end of a lightweight string in a horizontal circle at constant speed. Can the string ever be truly horizontal? If not, would it slope above the horizontal or below the horizontal? Why?

Q5.22 The centrifugal force is not included in the free-body diagrams of Figs. 5.34b and 5.35. Explain why not.

Q5.23 A professor swings a rubber stopper in a horizontal circle on the end of a string in front of his class. He tells Caroline, in the first row, that he is going to let the string go when the stopper is directly in front of her face. Should Caroline worry?

Q5.24 To keep the forces on the riders within allowable limits, loop-the-loop roller coaster rides are often designed so that the loop, rather than being a perfect circle, has a larger radius of curvature at the bottom than at the top. Explain.

Q5.25 A tennis ball drops from rest at the top of a tall glass cylinder, first with the air pumped out of the cylinder so there is no air resistance, and then a second time after the air has been readmitted to the cylinder. You examine multiframe photographs of the two drops. From these photos how can you tell which one is which, or can you?

Q5.26 If you throw a baseball straight upward with speed v_0 , how does its speed, when it returns to the point from where you threw it, compare to v_0 (a) in the absence of air resistance and (b) in the presence of air resistance? Explain.

Q5.27 You throw a baseball straight upward. If air resistance is *not* ignored, how does the time required for the ball to go from the height at which it was thrown up to its maximum height compare to the time required for it to fall from its maximum height back down to the height from which it was thrown? Explain your answer.

Q5.28 You take two identical tennis balls and fill one with water. You release both balls simultaneously from the top of a tall building. If air resistance is negligible, which ball strikes the ground first? Explain. What is the answer if air resistance is *not* negligible?

Q5.29 A ball is dropped from rest and feels air resistance as it falls. Which of the graphs in Fig. Q5.29 best represents its acceleration as a function of time?

Figure Q5.29

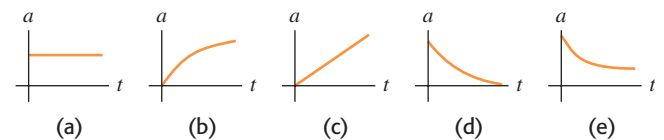

Q5.30 A ball is dropped from rest and feels air resistance as it falls. Which of the graphs in Fig. Q5.30 best represents its vertical velocity component as a function of time?

Figure Q5.30

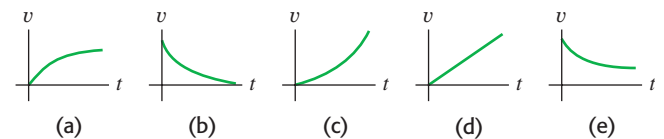

Q5.31 When does a baseball in flight have an acceleration with a positive upward component? Explain in terms of the forces on the ball and also in terms of the velocity components compared to the terminal speed. Do *not* ignore air resistance.

Q5.32 When a batted baseball moves with air drag, does it travel a greater horizontal distance while climbing to its maximum height or while descending from its maximum height back to the ground? Or is the horizontal distance traveled the same for both? Explain in terms of the forces acting on the ball.

Q5.33 "A ball is thrown from the edge of a high cliff. No matter what the angle at which it is thrown, due to air resistance, the ball will eventually end up moving vertically downward." Justify this statement.

EXERCISES

Section 5.1 Using Newton's First Law: Particles in Equilibrium

5.1 • Two 25.0-N weights are suspended at opposite ends of a rope that passes over a light, frictionless pulley. The pulley is attached to a chain that goes to the ceiling. (a) What is the tension in the rope? (b) What is the tension in the chain?

5.2 • In Fig. E5.2 each of the suspended blocks has weight w . The pulleys are frictionless and the ropes have negligible weight. Calculate, in each case, the tension T in the rope in terms of the weight w . In each case, include the free-body diagram or diagrams you used to determine the answer.

Figure E5.2

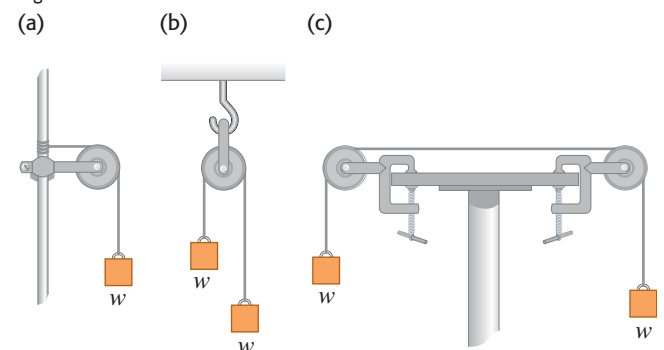

5.3 • A 75.0-kg wrecking ball hangs from a uniform heavy-duty chain having a mass of 26.0 kg. (a) Find the maximum and minimum tension in the chain. (b) What is the tension at a point three-fourths of the way up from the bottom of the chain?

5.4 •• BIO Injuries to the Spinal Column. In the treatment of spine injuries, it is often necessary to provide some tension along the spinal column to stretch the backbone. One device for doing this is the Stryker frame, illustrated in Fig. E5.4a. A weight W is attached to the patient (sometimes around a neck collar, as shown in Fig. E5.4b), and friction between the person's body and the bed prevents sliding. (a) If the coefficient of static friction between a 78.5-kg patient's body and the bed is 0.75, what is the maximum traction force along the spinal column that W can provide without causing the patient to slide? (b) Under the conditions of maximum traction, what is the tension in each cable attached to the neck collar?

Figure E5.4

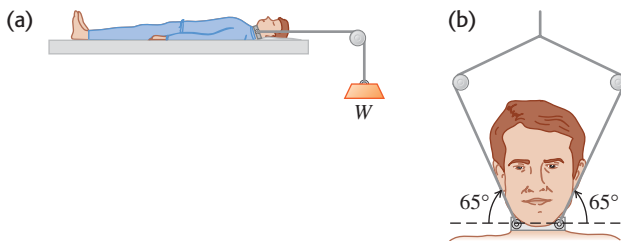

5.5 •• A picture frame hung against a wall is suspended by two wires attached to its upper corners. If the two wires make the same angle with the vertical, what must this angle be if the tension in each wire is equal to 0.75 of the weight of the frame? (Ignore any friction between the wall and the picture frame.)

5.6 •• A large wrecking ball is held in place by two light steel cables (Fig. E5.6). If the mass m of the wrecking ball is 4090 kg, what are (a) the tension T_B in the cable that makes an angle of 40° with the vertical and (b) the tension T_A in the horizontal cable?

Figure E5.6

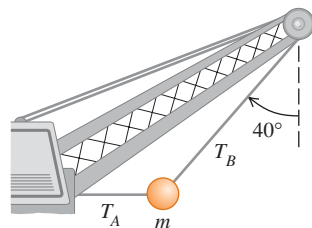

5.7 •• Find the tension in each cord in Fig. E5.7 if the weight of the suspended object is w .

Figure E5.7

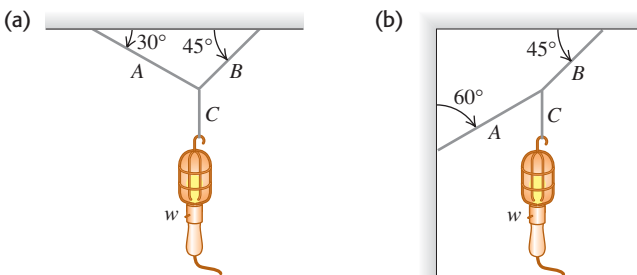

5.8 •• A 1130-kg car is held in place by a light cable on a very smooth (frictionless) ramp, as shown in Fig. E5.8. The cable

makes an angle of 31.0° above the surface of the ramp, and the ramp itself rises at 25.0° above the horizontal. (a) Draw a free-body diagram for the car. (b) Find the tension in the cable. (c) How hard does the surface of the ramp push on the car?

Figure E5.8

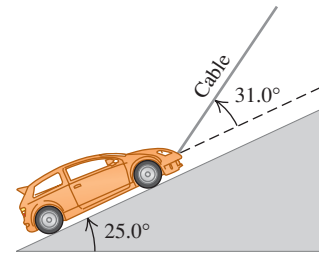

5.9 •• A man pushes on a piano with mass 180 kg so that it slides at constant velocity down a ramp that is inclined at 11.0° above the horizontal floor. Neglect any friction acting on the piano. Calculate the magnitude of the force applied by the man if he pushes (a) parallel to the incline and (b) parallel to the floor.

5.10 •• In Fig. E5.10 the weight w is 60.0 N. (a) What is the tension in the diagonal string? (b) Find the magnitudes of the horizontal forces \vec{F}_1 and \vec{F}_2 that must be applied to hold the system in the position shown.

Figure E5.10

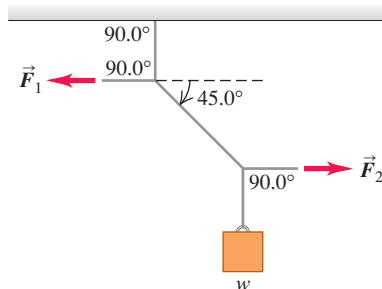

Section 5.2 Using Newton's Second Law: Dynamics of Particles

5.11 •• BIO Stay Awake! An astronaut is inside a 2.25×10^6 kg rocket that is blasting off vertically from the launch pad. You want this rocket to reach the speed of sound (331 m/s) as quickly as possible, but you also do not want the astronaut to black out. Medical tests have shown that astronauts are in danger of blacking out at an acceleration greater than $4g$. (a) What is the maximum thrust the engines of the rocket can have to just barely avoid blackout? Start with a free-body diagram of the rocket. (b) What force, in terms of her weight w , does the rocket exert on the astronaut? Start with a free-body diagram of the astronaut. (c) What is the shortest time it can take the rocket to reach the speed of sound?

5.12 •• A 125-kg (including all the contents) rocket has an engine that produces a constant vertical force (the *thrust*) of 1720 N. Inside this rocket, a 15.5-N electrical power supply rests on the floor. (a) Find the acceleration of the rocket. (b) When it has reached an altitude of 120 m, how hard does the floor push on the power supply? (*Hint:* Start with a free-body diagram for the power supply.)

5.13 •• CP Genesis Crash. On September 8, 2004, the *Genesis* spacecraft crashed in the Utah desert because its parachute did not open. The 210-kg capsule hit the ground at 311 km/h and penetrated the soil to a depth of 81.0 cm. (a) Assuming it to be constant, what was its acceleration (in m/s^2 and in g 's) during the crash? (b) What force did the ground exert on the capsule during the crash? Express the force in newtons and as a multiple of the capsule's weight. (c) For how long did this force last?

5.14 • Three sleds are being pulled horizontally on frictionless horizontal ice using horizontal ropes (Fig. E5.14). The pull is of magnitude 125 N. Find (a) the acceleration of the system and (b) the tension in ropes A and B.

Figure E5.14

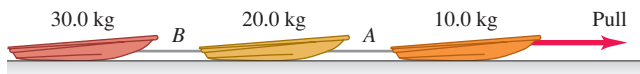

5.15 •• CP **Atwood's Machine.** A 15.0-kg load of bricks hangs from one end of a rope that passes over a small, frictionless pulley. A 28.0-kg counterweight is suspended from the other end of the rope, as shown in Fig. E5.15. The system is released from rest. (a) Draw two free-body diagrams, one for the load of bricks and one for the counterweight. (b) What is the magnitude of the upward acceleration of the load of bricks? (c) What is the tension in the rope while the load is moving? How does the tension compare to the weight of the load of bricks? To the weight of the counterweight?

Figure E5.15

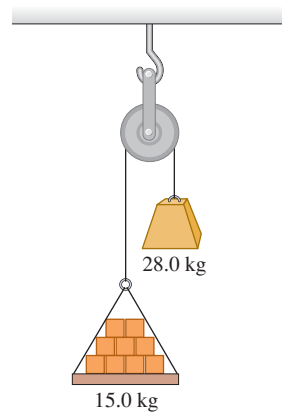

5.16 •• CP A 8.00-kg block of ice, released from rest at the top of a 1.50-m-long frictionless ramp, slides downhill, reaching a speed of 2.50 m/s at the bottom. (a) What is the angle between the ramp and the horizontal? (b) What would be the speed of the ice at the bottom if the motion were opposed by a constant friction force of 10.0 N parallel to the surface of the ramp?

5.17 •• A light rope is attached to a block with mass 4.00 kg that rests on a frictionless, horizontal surface. The horizontal rope passes over a frictionless, massless pulley, and a block with mass m is suspended from the other end. When the blocks are released, the tension in the rope is 10.0 N. (a) Draw two free-body diagrams, one for the 4.00-kg block and one for the block with mass m . (b) What is the acceleration of either block? (c) Find the mass m of the hanging block. (d) How does the tension compare to the weight of the hanging block?

5.18 •• CP Runway Design. A transport plane takes off from a level landing field with two gliders in tow, one behind the other. The mass of each glider is 700 kg, and the total resistance (air drag plus friction with the runway) on each may be assumed constant and equal to 2500 N. The tension in the towrope between the transport plane and the first glider is not to exceed 12,000 N. (a) If a speed of 40 m/s is required for takeoff, what minimum length of runway is needed? (b) What is the tension in the towrope between the two gliders while they are accelerating for the takeoff?

5.19 •• CP A 750.0-kg boulder is raised from a quarry 125 m deep by a long uniform chain having a mass of 575 kg. This chain is of uniform strength, but at any point it can support a maximum tension no greater than 2.50 times its weight without breaking. (a) What is the maximum acceleration the boulder can have and still get out of the quarry, and (b) how long does it take to be lifted out at maximum acceleration if it started from rest?

5.20 •• Apparent Weight. A 550-N physics student stands on a bathroom scale in an 850-kg (including the student) elevator that is supported by a cable. As the elevator starts moving, the scale reads

450 N. (a) Find the acceleration of the elevator (magnitude and direction). (b) What is the acceleration if the scale reads 670 N? (c) If the scale reads zero, should the student worry? Explain. (d) What is the tension in the cable in parts (a) and (c)?

5.21 •• CP BIO Force During a Jump. An average person can reach a maximum height of about 60 cm when jumping straight up from a crouched position. During the jump itself, the person's body from the knees up typically rises a distance of around 50 cm. To keep the calculations simple and yet get a reasonable result, assume that the *entire body* rises this much during the jump. (a) With what initial speed does the person leave the ground to reach a height of 60 cm? (b) Draw a free-body diagram of the person during the jump. (c) In terms of this jumper's weight w , what force does the ground exert on him or her during the jump?

5.22 •• CP CALC A 2540-kg test rocket is launched vertically from the launch pad. Its fuel (of negligible mass) provides a thrust force so that its vertical velocity as a function of time is given by $v(t) = At + Bt^2$, where A and B are constants and time is measured from the instant the fuel is ignited. At the instant of ignition, the rocket has an upward acceleration of 1.50 m/s^2 and 1.00 s later an upward velocity of 2.00 m/s. (a) Determine A and B , including their SI units. (b) At 4.00 s after fuel ignition, what is the acceleration of the rocket, and (c) what thrust force does the burning fuel exert on it, assuming no air resistance? Express the thrust in newtons and as a multiple of the rocket's weight. (d) What was the initial thrust due to the fuel?

5.23 •• CP CALC A 2.00-kg box is moving to the right with speed 9.00 m/s on a horizontal, frictionless surface. At $t = 0$ a horizontal force is applied to the box. The force is directed to the left and has magnitude $F(t) = (6.00 \text{ N/s}^2)t^2$. (a) What distance does the box move from its position at $t = 0$ before its speed is reduced to zero? (b) If the force continues to be applied, what is the speed of the box at $t = 3.00$ s?

5.24 •• CP CALC A 5.00-kg crate is suspended from the end of a short vertical rope of negligible mass. An upward force $F(t)$ is applied to the end of the rope, and the height of the crate above its initial position is given by $y(t) = (2.80 \text{ m/s})t + (0.610 \text{ m/s}^3)t^3$. What is the magnitude of the force F when $t = 4.00$ s?

Section 5.3 Frictional Forces

5.25 • BIO The Trendelenburg Position. In emergencies with major blood loss, the doctor will order the patient placed in the Trendelenburg position, in which the foot of the bed is raised to get maximum blood flow to the brain. If the coefficient of static friction between the typical patient and the bedsheets is 1.20, what is the maximum angle at which the bed can be tilted with respect to the floor before the patient begins to slide?

5.26 • In a laboratory experiment on friction, a 135-N block resting on a rough horizontal table is pulled by a horizontal wire. The pull gradually increases until the block begins to move and continues to increase thereafter. Figure E5.26 shows a graph of the friction force on this block as a function of the pull. (a) Identify the

Figure E5.26

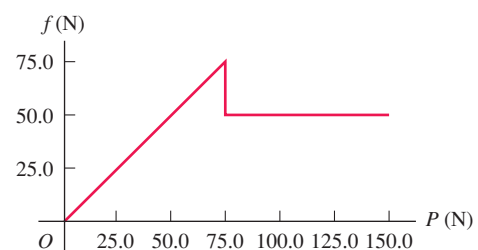

regions of the graph where static and kinetic friction occur. (b) Find the coefficients of static and kinetic friction between the block and the table. (c) Why does the graph slant upward in the first part but then level out? (d) What would the graph look like if a 135-N brick were placed on the box, and what would the coefficients of friction be in that case?

5.27 •• CP A stockroom worker pushes a box with mass 11.2 kg on a horizontal surface with a constant speed of 3.50 m/s. The coefficient of kinetic friction between the box and the surface is 0.20. (a) What horizontal force must the worker apply to maintain the motion? (b) If the force calculated in part (a) is removed, how far does the box slide before coming to rest?

5.28 •• A box of bananas weighing 40.0 N rests on a horizontal surface. The coefficient of static friction between the box and the surface is 0.40, and the coefficient of kinetic friction is 0.20. (a) If no horizontal force is applied to the box and the box is at rest, how large is the friction force exerted on the box? (b) What is the magnitude of the friction force if a monkey applies a horizontal force of 6.0 N to the box and the box is initially at rest? (c) What minimum horizontal force must the monkey apply to start the box in motion? (d) What minimum horizontal force must the monkey apply to keep the box moving at constant velocity once it has been started? (e) If the monkey applies a horizontal force of 18.0 N, what is the magnitude of the friction force and what is the box's acceleration?

5.29 •• A 45.0-kg crate of tools rests on a horizontal floor. You exert a gradually increasing horizontal push on it and observe that the crate just begins to move when your force exceeds 313 N. After that you must reduce your push to 208 N to keep it moving at a steady 25.0 cm/s. (a) What are the coefficients of static and kinetic friction between the crate and the floor? (b) What push must you exert to give it an acceleration of 1.10 m/s^2 ? (c) Suppose you were performing the same experiment on this crate but were doing it on the moon instead, where the acceleration due to gravity is 1.62 m/s^2 . (i) What magnitude push would cause it to move? (ii) What would its acceleration be if you maintained the push in part (b)?

5.30 •• Some sliding rocks approach the base of a hill with a speed of 12 m/s. The hill rises at 36° above the horizontal and has coefficients of kinetic and static friction of 0.45 and 0.65, respectively, with these rocks. (a) Find the acceleration of the rocks as they slide up the hill. (b) Once a rock reaches its highest point, will it stay there or slide down the hill? If it stays there, show why. If it slides down, find its acceleration on the way down.

5.31 •• You are lowering two boxes, one on top of the other, down the ramp shown in Fig. E5.31 by pulling on a rope parallel to the surface of the ramp. Both boxes move together at a constant speed of 15.0 cm/s. The coefficient of kinetic friction between the ramp and the lower box is 0.444, and the coefficient of static friction between the two boxes is 0.800. (a) What force do you need to exert to accomplish this? (b) What are the magnitude and direction of the friction force on the upper box?

Figure E5.31

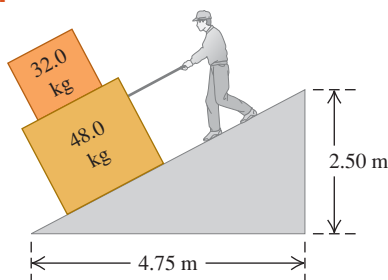

5.32 •• A pickup truck is carrying a toolbox, but the rear gate of the truck is missing, so the box will slide out if it is set moving. The coefficients of kinetic and static friction between the box and the bed of the truck are 0.355 and 0.650, respectively. Starting from rest, what is the shortest time this truck could accelerate uniformly to 30.0 m/s without causing the box to slide? Include a free-body diagram of the toolbox as part of your solution.

5.33 •• CP Stopping Distance. (a) If the coefficient of kinetic friction between tires and dry pavement is 0.80, what is the shortest distance in which you can stop an automobile by locking the brakes when traveling at 28.7 m/s (about 65 mi/h)? (b) On wet pavement the coefficient of kinetic friction may be only 0.25. How fast should you drive on wet pavement in order to be able to stop in the same distance as in part (a)? (*Note:* Locking the brakes is *not* the safest way to stop.)

5.34 •• Consider the system shown in Fig. E5.34. Block A weighs 45.0 N and block B weighs 25.0 N. Once block B is set into downward motion, it descends at a constant

Figure E5.34

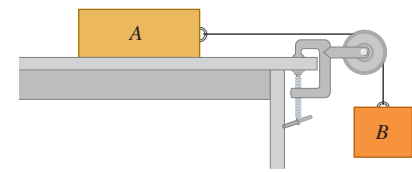

speed. (a) Calculate the coefficient of kinetic friction between block A and the tabletop. (b) A cat, also of weight 45.0 N, falls asleep on top of block A. If block B is now set into downward motion, what is its acceleration (magnitude and direction)?

5.35 • Two crates connected by a rope lie on a horizontal surface (Fig. E5.35). Crate A has mass m_A and crate B has mass m_B . The coefficient of kinetic friction between each crate and the surface is μ_k . The crates are pulled to the right at constant velocity by a horizontal force \vec{F} . In terms of m_A , m_B , and μ_k , calculate (a) the magnitude of the force \vec{F} and (b) the tension in the rope connecting the blocks. Include the free-body diagram or diagrams you used to determine each answer.

Figure E5.35

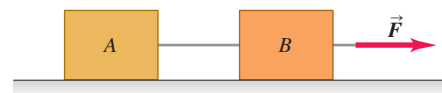

5.36 •• CP A 25.0-kg box of textbooks rests on a loading ramp that makes an angle α with the horizontal. The coefficient of kinetic friction is 0.25, and the coefficient of static friction is 0.35. (a) As the angle α is increased, find the minimum angle at which the box starts to slip. (b) At this angle, find the acceleration once the box has begun to move. (c) At this angle, how fast will the box be moving after it has slid 5.0 m along the loading ramp?

5.37 •• CP As shown in Fig. E5.34, block A (mass 2.25 kg) rests on a tabletop. It is connected by a horizontal cord passing over a light, frictionless pulley to a hanging block B (mass 1.30 kg). The coefficient of kinetic friction between block A and the tabletop is 0.450. After the blocks are released from rest, find (a) the speed of each block after moving 3.00 cm and (b) the tension in the cord. Include the free-body diagram or diagrams you used to determine the answers.

5.38 •• A box with mass m is dragged across a level floor having a coefficient of kinetic friction μ_k by a rope that is pulled upward at an angle θ above the horizontal with a force of magnitude F . (a) In terms of m , μ_k , θ , and g , obtain an expression for the magnitude of the force required to move the box with constant speed. (b) Knowing that you are studying physics, a CPR instructor asks you

how much force it would take to slide a 90-kg patient across a floor at constant speed by pulling on him at an angle of 25° above the horizontal. By dragging some weights wrapped in an old pair of pants down the hall with a spring balance, you find that $\mu_k = 0.35$. Use the result of part (a) to answer the instructor's question.

5.39 •• A large crate with mass m rests on a horizontal floor. The coefficients of friction between the crate and the floor are μ_s and μ_k . A woman pushes downward at an angle θ below the horizontal on the crate with a force \vec{F} . (a) What magnitude of force \vec{F} is required to keep the crate moving at constant velocity? (b) If μ_s is greater than some critical value, the woman cannot start the crate moving no matter how hard she pushes. Calculate this critical value of μ_s .

5.40 •• You throw a baseball straight up. The drag force is proportional to v^2 . In terms of g , what is the y -component of the ball's acceleration when its speed is half its terminal speed and (a) it is moving up? (b) It is moving back down?

5.41 • (a) In Example 5.18 (Section 5.3), what value of D is required to make $v_t = 42$ m/s for the skydiver? (b) If the skydiver's daughter, whose mass is 45 kg, is falling through the air and has the same D (0.25 kg/m) as her father, what is the daughter's terminal speed?

Section 5.4 Dynamics of Circular Motion

5.42 •• A small car with mass 0.800 kg travels at constant speed on the inside of a track that is a vertical circle with radius 5.00 m (Fig. E5.42). If the normal force exerted by the track on the car when it is at the top of the track (point B) is 6.00 N, what is the normal force on the car when it is at the bottom of the track (point A)?

Figure E5.42

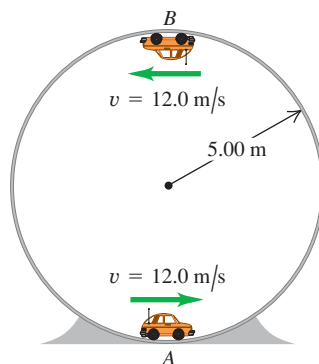

5.43 •• A machine part consists of a thin 40.0-cm-long bar with small 1.15-kg masses fastened by screws to its ends. The screws can support a maximum force of 75.0 N without pulling out. This bar rotates about an axis perpendicular to it at its center. (a) As the bar is turning at a constant rate on a horizontal, frictionless surface, what is the maximum speed the masses can have without pulling out the screws? (b) Suppose the machine is redesigned so that the bar turns at a constant rate in a vertical circle. Will one of the screws be more likely to pull out when the mass is at the top of the circle or at the bottom? Use a free-body diagram to see why. (c) Using the result of part (b), what is the greatest speed the masses can have without pulling a screw?

5.44 • A flat (unbanked) curve on a highway has a radius of 220.0 m. A car rounds the curve at a speed of 25.0 m/s. (a) What is the minimum coefficient of friction that will prevent sliding? (b) Suppose the highway is icy and the coefficient of friction between the tires and pavement is only one-third what you found in part (a). What should be the maximum speed of the car so it can round the curve safely?

5.45 •• A 1125-kg car and a 2250-kg pickup truck approach a curve on the expressway that has a radius of 225 m. (a) At what angle should the highway engineer bank this curve so that vehicles traveling at 65.0 mi/h can safely round it regardless of the condition of their tires? Should the heavy truck go slower than the

lighter car? (b) As the car and truck round the curve at find the normal force on each one due to the highway surface.

5.46 •• The "Giant Swing" at a county fair consists of a vertical central shaft with a number of horizontal arms attached at its upper end (Fig. E5.46). Each arm supports a seat suspended from a cable 5.00 m long, the upper end of the cable being fastened to the arm at a point 3.00 m from the central shaft. (a) Find the time of one revolution of the swing if the cable supporting a seat makes an angle of 30.0° with the vertical. (b) Does the angle depend on the weight of the passenger for a given rate of revolution?

Figure E5.46

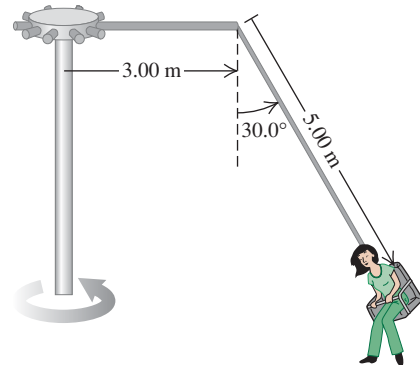

5.47 •• In another version of the "Giant Swing" (see Exercise 5.46), the seat is connected to two cables as shown in Fig. E5.47, one of which is horizontal. The seat swings in a horizontal circle at a rate of 32.0 rpm (rev/min). If the seat weighs 255 N and an 825-N person is sitting in it, find the tension in each cable.

Figure E5.47

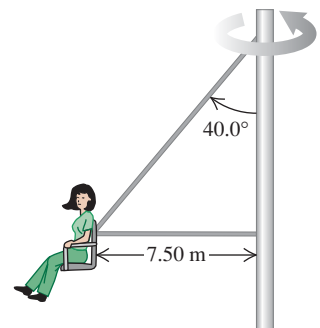

5.48 •• A small button placed on a horizontal rotating platform with diameter 0.320 m will revolve with the platform when it is brought up to a speed of 40.0 rev/min, provided the button is no more than 0.150 m from the axis. (a) What is the coefficient of static friction between the button and the platform? (b) How far from the axis can the button be placed, without slipping, if the platform rotates at 60.0 rev/min?

5.49 •• Rotating Space Stations. One problem for humans living in outer space is that they are apparently weightless. One way around this problem is to design a space station that spins about its center at a constant rate. This creates "artificial gravity" at the outside rim of the station. (a) If the diameter of the space station is 800 m, how many revolutions per minute are needed for the "artificial gravity" acceleration to be 9.80 m/s²? (b) If the space station is a waiting area for travelers going to Mars, it might be desirable to simulate the acceleration due to gravity on the Martian surface (3.70 m/s²). How many revolutions per minute are needed in this case?

5.50 • The Cosmoclock 21 Ferris wheel in Yokohama City, Japan, has a diameter of 100 m. Its name comes from its 60 arms, each of which can function as a second hand (so that it makes one revolution every 60.0 s). (a) Find the speed of the passengers when the Ferris wheel is rotating at this rate. (b) A passenger

weighs 882 N at the weight-guessing booth on the ground. What is his apparent weight at the highest and at the lowest point on the Ferris wheel? (c) What would be the time for one revolution if the passenger's apparent weight at the highest point were zero? (d) What then would be the passenger's apparent weight at the lowest point?

5.51 •• An airplane flies in a loop (a circular path in a vertical plane) of radius 150 m. The pilot's head always points toward the center of the loop. The speed of the airplane is not constant; the airplane goes slowest at the top of the loop and fastest at the bottom. (a) At the top of the loop, the pilot feels weightless. What is the speed of the airplane at this point? (b) At the bottom of the loop, the speed of the airplane is 280 km/h. What is the apparent weight of the pilot at this point? His true weight is 700 N.

5.52 •• A 50.0-kg stunt pilot who has been diving her airplane vertically pulls out of the dive by changing her course to a circle in a vertical plane. (a) If the plane's speed at the lowest point of the circle is 95.0 m/s, what is the minimum radius of the circle for the acceleration at this point not to exceed $4.00g$? (b) What is the apparent weight of the pilot at the lowest point of the pullout?

5.53 • Stay Dry! You tie a cord to a pail of water, and you swing the pail in a vertical circle of radius 0.600 m. What minimum speed must you give the pail at the highest point of the circle if no water is to spill from it?

5.54 •• A bowling ball weighing 71.2 N (16.0 lb) is attached to the ceiling by a 3.80-m rope. The ball is pulled to one side and released; it then swings back and forth as a pendulum. As the rope swings through the vertical, the speed of the bowling ball is 4.20 m/s. (a) What is the acceleration of the bowling ball, in magnitude and direction, at this instant? (b) What is the tension in the rope at this instant?

5.55 •• BIO Effect on Blood of Walking. While a person is walking, his arms swing through approximately a 45° angle in $\frac{1}{2}$ s. As a reasonable approximation, we can assume that the arm moves with constant speed during each swing. A typical arm is 70.0 cm long, measured from the shoulder joint. (a) What is the acceleration of a 1.0-g drop of blood in the fingertips at the bottom of the swing? (b) Draw a free-body diagram of the drop of blood in part (a). (c) Find the force that the blood vessel must exert on the drop of blood in part (a). Which way does this force point? (d) What force would the blood vessel exert if the arm were not swinging?

PROBLEMS

5.56 •• An adventurous archaeologist crosses between two rock cliffs by slowly going hand over hand along a rope stretched between the cliffs. He stops to rest at the middle of the rope (Fig. P5.56). The rope will break if the tension in it exceeds 2.50×10^4 N, and our hero's mass is 90.0 kg. (a) If the angle θ is 10.0° , find the tension in the rope. (b) What is the smallest value the angle θ can have if the rope is not to break?

Figure P5.56

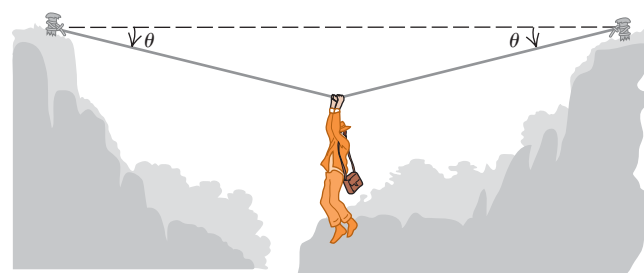

5.57 ••• Two ropes are connected to a steel cable that supports a hanging weight as shown in Fig. P5.57. (a) Draw a free-body diagram showing all of the forces acting at the knot that connects the two ropes to the steel cable. Based on your force diagram, which of the two ropes will have the greater tension? (b) If the maximum tension either rope can sustain without breaking is 5000 N, determine the maximum value of the hanging weight that these ropes can safely support. You can ignore the weight of the ropes and the steel cable.

Figure P5.57

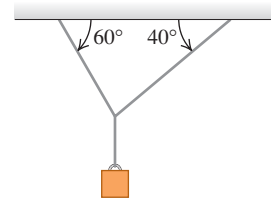

5.58 •• In Fig. P5.58 a worker lifts a weight w by pulling down on a rope with a force \vec{F} . The upper pulley is attached to the ceiling by a chain, and the lower pulley is attached to the weight by another chain. In terms of w , find the tension in each chain and the magnitude of the force \vec{F} if the weight is lifted at constant speed. Include the free-body diagram or diagrams you used to determine your answers. Assume that the rope, pulleys, and chains all have negligible weights.

Figure P5.58

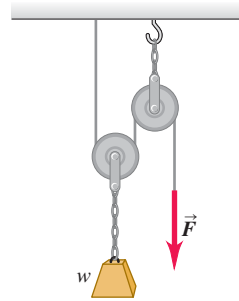

Figure P5.59

5.59 ••• A solid uniform 45.0-kg ball of diameter 32.0 cm is supported against a vertical, frictionless wall using a thin 30.0-cm wire of negligible mass, as shown in Fig. P5.59. (a) Draw a free-body diagram for the ball and use it to find the tension in the wire. (b) How hard does the ball push against the wall?

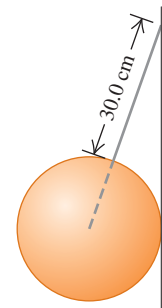
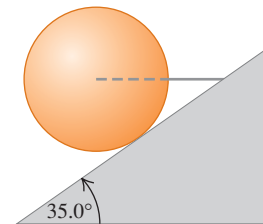

Figure P5.60

5.60 ••• A horizontal wire holds a solid uniform ball of mass m in place on a tilted ramp that rises 35.0° above the horizontal. The surface of this ramp is perfectly smooth, and the wire is directed away from the center of the ball (Fig. P5.60). (a) Draw a free-body diagram for the ball. (b) How hard does the surface of the ramp push on the ball? (c) What is the tension in the wire?



5.61 •• CP BIO Forces During Chin-ups. People who do chin-ups raise their chin just over a bar (the chinning bar), supporting themselves with only their arms. Typically, the body below the arms is raised by about 30 cm in a time of 1.0 s, starting from rest. Assume that the entire body of a 680-N person doing chin-ups is raised this distance and that half the 1.0 s is spent accelerating upward and the other half accelerating downward, uniformly in both cases. Draw a free-body diagram of the person's body, and then apply it to find the force his arms must exert on him during the accelerating part of the chin-up.

5.62 •• CP BIO Prevention of Hip Injuries. People (especially the elderly) who are prone to falling can wear hip pads to

cushion the impact on their hip from a fall. Experiments have shown that if the speed at impact can be reduced to 1.3 m/s or less, the hip will usually not fracture. Let us investigate the worst-case scenario in which a 55-kg person completely loses her footing (such as on icy pavement) and falls a distance of 1.0 m, the distance from her hip to the ground. We shall assume that the person's entire body has the same acceleration, which, in reality, would not quite be true. (a) With what speed does her hip reach the ground? (b) A typical hip pad can reduce the person's speed to 1.3 m/s over a distance of 2.0 cm. Find the acceleration (assumed to be constant) of this person's hip while she is slowing down and the force the pad exerts on it. (c) The force in part (b) is very large. To see whether it is likely to cause injury, calculate how long it lasts.

5.63 ••• CALC A 3.00-kg box that is several hundred meters above the surface of the earth is suspended from the end of a short vertical rope of negligible mass. A time-dependent upward force is applied to the upper end of the rope, and this results in a tension in the rope of $T(t) = (36.0 \text{ N/s})t$. The box is at rest at $t = 0$. The only forces on the box are the tension in the rope and gravity. (a) What is the velocity of the box at (i) $t = 1.00 \text{ s}$ and (ii) $t = 3.00 \text{ s}$? (b) What is the maximum distance that the box descends below its initial position? (c) At what value of t does the box return to its initial position?

5.64 •• CP A 5.00-kg box sits at rest at the bottom of a ramp that is 8.00 m long and that is inclined at 30.0° above the horizontal. The coefficient of kinetic friction is $\mu_k = 0.40$, and the coefficient of static friction is $\mu_s = 0.50$. What constant force F , applied parallel to the surface of the ramp, is required to push the box to the top of the ramp in a time of 4.00 s?

5.65 •• Two boxes connected by a light horizontal rope are on a horizontal surface, as shown in Fig. P5.35. The coefficient of kinetic friction between each box and the surface is $\mu_k = 0.30$. One box (box B) has mass 5.00 kg, and the other box (box A) has mass m . A force F with magnitude 40.0 N and direction 53.1° above the horizontal is applied to the 5.00-kg box, and both boxes move to the right with $a = 1.50 \text{ m/s}^2$. (a) What is the tension T in the rope that connects the boxes? (b) What is the mass m of the second box?

5.66 ••• A 6.00-kg box sits on a ramp that is inclined at 37.0° above the horizontal. The coefficient of kinetic friction between the box and the ramp is $\mu_k = 0.30$. What horizontal force is required to move the box up the incline with a constant acceleration of 4.20 m/s^2 ?

5.67 •• CP In Fig. P5.34 block A has mass m and block B has mass 6.00 kg. The coefficient of kinetic friction between block A and the tabletop is $\mu_k = 0.40$. The mass of the rope connecting the blocks can be neglected. The pulley is light and frictionless. When the system is released from rest, the hanging block descends 5.00 m in 3.00 s. What is the mass m of block A?

5.68 •• CP In Fig. P5.68 $m_1 = 20.0 \text{ kg}$ and $\alpha = 53.1^\circ$. The coefficient of kinetic friction between the block and the incline is $\mu_k = 0.40$. What must be the mass m_2 of the hanging block if it is to descend 12.0 m in the first 3.00 s after the system is released from rest?

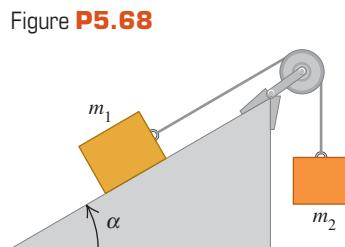

Figure P5.68

5.69 ••• CP Rolling Friction. Two bicycle tires are set rolling with the same initial speed of 3.50 m/s on a long, straight road, and the distance each travels before its speed is reduced by half is measured. One tire is inflated to a pressure of 40 psi and goes 18.1 m; the other is at 105 psi and goes 92.9 m. What is the coefficient of rolling friction μ_r for each? Assume that the net horizontal force is due to rolling friction only.

5.70 •• A Rope with Mass. A block with mass M is attached to the lower end of a vertical, uniform rope with mass m and length L . A constant upward force \vec{F} is applied to the top of the rope, causing the rope and block to accelerate upward. Find the tension in the rope at a distance x from the top end of the rope, where x can have any value from 0 to L .

5.71 •• A block with mass m_1 is placed on an inclined plane with slope angle α and is connected to a second hanging block with mass m_2 by a cord passing over a small, frictionless pulley (Fig. P5.68). The coefficient of static friction is μ_s and the coefficient of kinetic friction is μ_k . (a) Find the mass m_2 for which block m_1 moves up the plane at constant speed once it is set in motion. (b) Find the mass m_2 for which block m_1 moves down the plane at constant speed once it is set in motion. (c) For what range of values of m_2 will the blocks remain at rest if they are released from rest?

5.72 •• Block A in Fig. P5.72 weighs 60.0 N. The coefficient of static friction between the block and the surface on which it rests is 0.25. The weight w is 12.0 N and the system is in equilibrium. (a) Find the friction force exerted on block A. (b) Find the maximum weight w for which the system will remain in equilibrium.

Figure P5.72

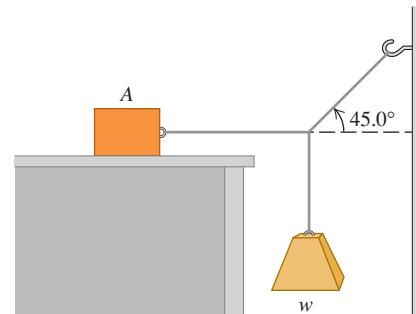

5.73 •• Block A in Fig. P5.73 weighs 2.40 N and block B weighs 3.60 N. The coefficient of kinetic friction between all surfaces is 0.300. Find the magnitude of the horizontal force \vec{F} necessary to drag block B to the left at constant speed (a) if A rests on B and moves with it (Fig. P5.73a). (b) If A is held at rest (Fig. P5.73b).

Figure P5.73

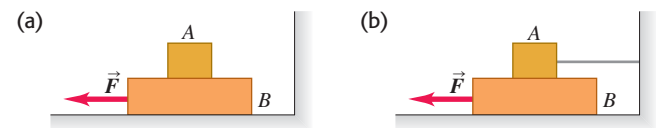

5.74 ••• A window washer pushes his scrub brush up a vertical window at constant speed by applying a force \vec{F} as shown in Fig. P5.74. The brush weighs 15.0 N and the coefficient of kinetic friction is $\mu_k = 0.150$. Calculate (a) the magnitude of the force \vec{F} and (b) the normal force exerted by the window on the brush.

Figure P5.74

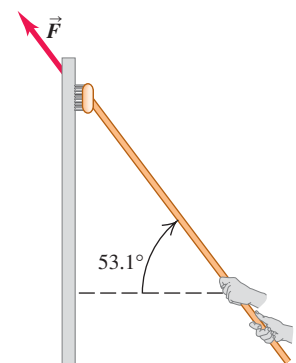

5.75 ••• BIO The Flying Leap of a Flea. High-speed motion pictures (3500 frames/second) of a jumping 210- μg flea yielded the data to plot the flea's acceleration as a function of time as

shown in Fig. P5.75. (See “The Flying Leap of the Flea,” by M. Rothschild et al. in the November 1973 *Scientific American*.) This flea was about 2 mm long and jumped at a nearly vertical takeoff angle. Use the measurements shown on the graph to answer the questions. (a) Find the *initial* net external force on the flea. How does it compare to the flea’s weight? (b) Find the *maximum* net external force on this jumping flea. When does this maximum force occur? (c) Use the graph to find the flea’s maximum speed.

Figure P5.75

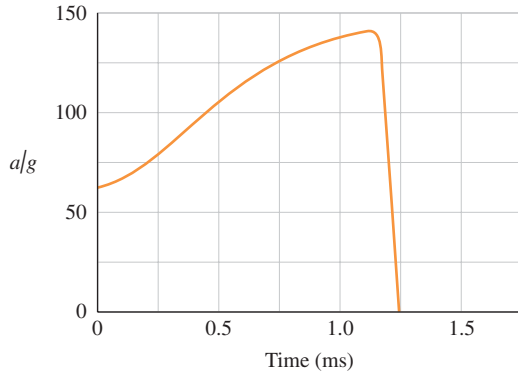

5.76 •• CP A 25,000-kg rocket blasts off vertically from the earth’s surface with a constant acceleration. During the motion considered in the problem, assume that g remains constant (see Chapter 13). Inside the rocket, a 15.0-N instrument hangs from a wire that can support a maximum tension of 45.0 N. (a) Find the minimum time for this rocket to reach the sound barrier (330 m/s) without breaking the inside wire and the maximum vertical thrust of the rocket engines under these conditions. (b) How far is the rocket above the earth’s surface when it breaks the sound barrier?

5.77 •• CP CALC You are standing on a bathroom scale in an elevator in a tall building. Your mass is 64 kg. The elevator starts from rest and travels upward with a speed that varies with time according to $v(t) = (3.0 \text{ m/s}^2)t + (0.20 \text{ m/s}^3)t^2$. When $t = 4.0 \text{ s}$, what is the reading of the bathroom scale?

5.78 •• CP Elevator Design. You are designing an elevator for a hospital. The force exerted on a passenger by the floor of the elevator is not to exceed 1.60 times the passenger’s weight. The elevator accelerates upward with constant acceleration for a distance of 3.0 m and then starts to slow down. What is the maximum speed of the elevator?

5.79 •• CP You are working for a shipping company. Your job is to stand at the bottom of a 8.0-m-long ramp that is inclined at 37° above the horizontal. You grab packages off a conveyor belt and propel them up the ramp. The coefficient of kinetic friction between the packages and the ramp is $\mu_k = 0.30$. (a) What speed do you need to give a package at the bottom of the ramp so that it has zero speed at the top of the ramp? (b) Your coworker is supposed to grab the packages as they arrive at the top of the ramp, but she misses one and it slides back down. What is its speed when it returns to you?

5.80 •• A hammer is hanging by a light rope from the ceiling of a bus. The ceiling of the bus is parallel to the roadway. The bus is traveling in a straight line on a horizontal street. You observe that the hammer hangs at rest with respect to the bus when the angle between the rope and the ceiling of the bus is 67° . What is the acceleration of the bus?

5.81 ••• A steel washer is suspended inside an empty shipping crate from a light string attached to the top of the crate. The crate slides down a long ramp that is inclined at an angle of 37° above the horizontal. The crate has mass 180 kg. You are sitting inside the crate

(with a flashlight); your mass is 55 kg. As the crate is sliding down the ramp, you find the washer is at rest with respect to the crate when the string makes an angle of 68° with the top of the crate. What is the coefficient of kinetic friction between the ramp and the crate?

5.82 • CP Lunch Time! You are riding your motorcycle one day down a wet street that slopes downward at an angle of 20° below the horizontal. As you start to ride down the hill, you notice a construction crew has dug a deep hole in the street at the bottom of the hill. A Siberian tiger, escaped from the City Zoo, has taken up residence in the hole. You apply the brakes and lock your wheels at the top of the hill, where you are moving with a speed of 20 m/s. The inclined street in front of you is 40 m long. (a) Will you plunge into the hole and become the tiger’s lunch, or do you skid to a stop before you reach the hole? (The coefficients of friction between your motorcycle tires and the wet pavement are $\mu_s = 0.90$ and $\mu_k = 0.70$.) (b) What must your initial speed be if you are to stop just before reaching the hole?

5.83 ••• In the system shown in Fig. P5.34, block A has mass m_A , block B has mass m_B , and the rope connecting them has a *nonzero* mass m_{rope} . The rope has a total length L , and the pulley has a very small radius. You can ignore any sag in the horizontal part of the rope. (a) If there is no friction between block A and the tabletop, find the acceleration of the blocks at an instant when a length d of rope hangs vertically between the pulley and block B . As block B falls, will the magnitude of the acceleration of the system increase, decrease, or remain constant? Explain. (b) Let $m_A = 2.00 \text{ kg}$, $m_B = 0.400 \text{ kg}$, $m_{\text{rope}} = 0.160 \text{ kg}$, and $L = 1.00 \text{ m}$. If there is friction between block A and the tabletop, with $\mu_k = 0.200$ and $\mu_s = 0.250$, find the minimum value of the distance d such that the blocks will start to move if they are initially at rest. (c) Repeat part (b) for the case $m_{\text{rope}} = 0.040 \text{ kg}$. Will the blocks move in this case?

5.84 ••• If the coefficient of static friction between a table and a uniform massive rope is μ_s , what fraction of the rope can hang over the edge of the table without the rope sliding?

5.85 •• A 40.0-kg packing case is initially at rest on the floor of a 1500-kg pickup truck. The coefficient of static friction between the case and the truck floor is 0.30, and the coefficient of kinetic friction is 0.20. Before each acceleration given below, the truck is traveling due north at constant speed. Find the magnitude and direction of the friction force acting on the case (a) when the truck accelerates at 2.20 m/s^2 northward and (b) when it accelerates at 3.40 m/s^2 southward.

5.86 • CP Traffic Court. You are called as an expert witness in the trial of a traffic violation. The facts are these: A driver slammed on his brakes and came to a stop with constant acceleration. Measurements of his tires and the skid marks on the pavement indicate that he locked his car’s wheels, the car traveled 192 ft before stopping, and the coefficient of kinetic friction between the road and his tires was 0.750. The charge is that he was speeding in a 45-mi/h zone. He pleads innocent. What is your conclusion, guilty or innocent? How fast was he going when he hit his brakes?

5.87 ••• Two identical 15.0-kg balls, each 25.0 cm in diameter, are suspended by two 35.0-cm wires as shown in Fig. P5.87. The entire apparatus is supported by a single 18.0-cm wire, and the surfaces of the balls are perfectly smooth. (a) Find the tension in each of the three wires. (b) How hard does each ball push on the other one?

Figure P5.87

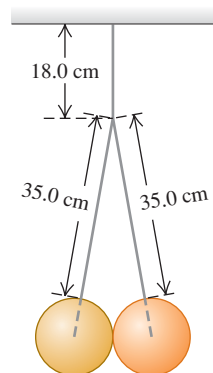

5.88 •• CP Losing Cargo. A 12.0-kg box rests on the flat floor of a truck. The coefficients of friction between the box and floor are $\mu_s = 0.19$ and $\mu_k = 0.15$. The truck stops at a stop sign and then starts to move with an acceleration of 2.20 m/s^2 . If the box is 1.80 m from the rear of the truck when the truck starts, how much time elapses before the box falls off the truck? How far does the truck travel in this time?

5.89 ••• Block A in Fig. Figure P5.89

P5.89 weighs 1.90 N, and block B weighs 4.20 N. The coefficient of kinetic friction between all surfaces is 0.30. Find the magnitude of the horizontal force \vec{F} necessary to drag block B to the left at constant speed if A and B are connected by a light, flexible cord passing around a fixed, frictionless pulley.

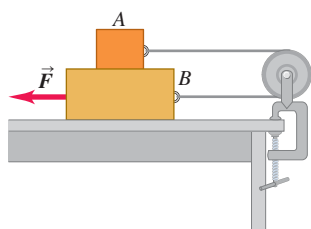

5.90 ••• CP You are part of a design team for future exploration of the planet Mars, where $g = 3.7 \text{ m/s}^2$. An explorer is to step out of a survey vehicle traveling horizontally at 33 m/s when it is 1200 m above the surface and then fall freely for 20 s. At that time, a portable advanced propulsion system (PAPS) is to exert a constant force that will decrease the explorer's speed to zero at the instant she touches the surface. The total mass (explorer, suit, equipment, and PAPS) is 150 kg. Assume the change in mass of the PAPS to be negligible. Find the horizontal and vertical components of the force the PAPS must exert, and for what interval of time the PAPS must exert it. You can ignore air resistance.

5.91 •• Block A in Fig. P5.91 has a mass of 4.00 kg, and block B has mass 12.0 kg. The coefficient of kinetic friction between block B and the horizontal surface is 0.25. (a) What is the mass of block C if block B is moving to the right and speeding up with an acceleration of 2.00 m/s^2 ? (b) What is the tension in each cord when block B has this acceleration?

Figure P5.91

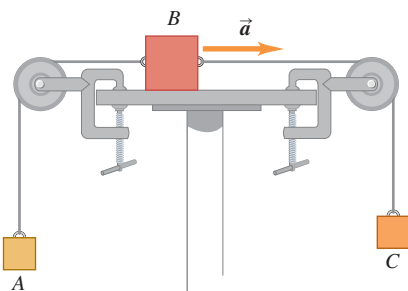

5.92 •• Two blocks connected by a cord passing over a small, frictionless pulley rest on frictionless planes (Fig. P5.92). (a) Which way will the system move when the blocks are released from rest? (b) What is the acceleration of the blocks? (c) What is the tension in the cord?

Figure P5.92

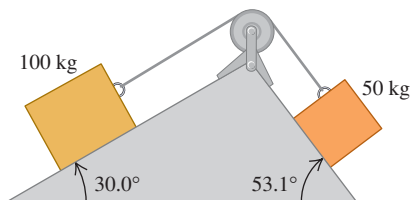

5.93 •• In terms of m_1 , Figure P5.93

m_2 , and g , find the acceleration of each block in Fig. P5.93. There is no friction anywhere in the system.

5.94 ••• Block B, with mass 5.00 kg, rests on block A, with mass 8.00 kg, which in turn is on a horizontal tabletop (Fig. P5.94). There is no friction between block A and the tabletop, but the coefficient of static friction between block A and block B is 0.750. A light string attached to block A passes over a frictionless, massless pulley, and block C is suspended from the other end of the string. What is the largest mass that block C can have so that blocks A and B still slide together when the system is released from rest?

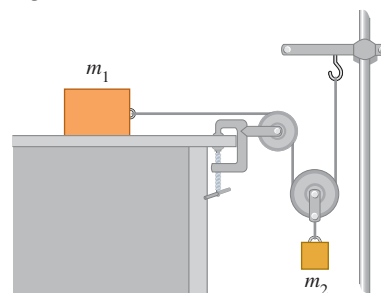
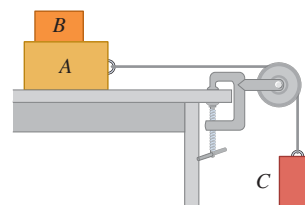

Figure P5.94



5.95 ••• Two objects with masses 5.00 kg and 2.00 kg hang 0.600 m above the floor from the ends of a cord 6.00 m long passing over a frictionless pulley. Both objects start from rest. Find the maximum height reached by the 2.00-kg object.

5.96 •• Friction in an Elevator. You are riding in an elevator on the way to the 18th floor of your dormitory. The elevator is accelerating upward with $a = 1.90 \text{ m/s}^2$. Beside you is the box containing your new computer; the box and its contents have a total mass of 28.0 kg. While the elevator is accelerating upward, you push horizontally on the box to slide it at constant speed toward the elevator door. If the coefficient of kinetic friction between the box and the elevator floor is $\mu_k = 0.32$, what magnitude of force must you apply?

5.97 • A block is placed against the vertical front of a cart as shown in Fig. P5.97. What acceleration must the cart have so that block A does not fall? The coefficient of static friction between the block and the cart is μ_s . How would an observer on the cart describe the behavior of the block?

Figure P5.97

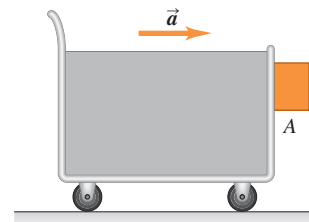
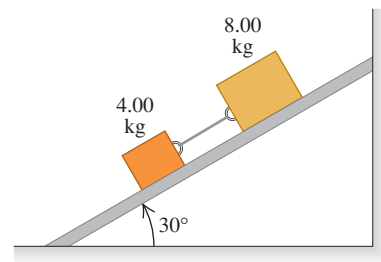

Figure P5.98



5.98 ••• Two blocks with masses 4.00 kg and 8.00 kg are connected by a string and slide down a 30.0° inclined plane (Fig. P5.98). The coefficient of kinetic friction between the

4.00-kg block and the plane is 0.25; that between the 8.00-kg block and the plane is 0.35. (a) Calculate the acceleration of each block. (b) Calculate the tension in the string. (c) What happens if the positions of the blocks are reversed, so the 4.00-kg block is above the 8.00-kg block?

5.99 ••• Block A, with weight $3w$, slides down an inclined plane S of slope angle 36.9° at a constant speed while plank B , with weight w , rests on top of A. The plank is attached by a cord to the wall (Fig. P5.99).

(a) Draw a diagram of all the forces acting on block A. (b) If the coefficient of kinetic friction is the same between A and B and between S and A, determine its value.

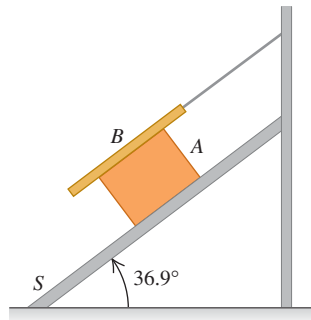

5.100 •• Accelerometer. The system shown in Fig. P5.100 can be used to measure the acceleration of the system. An observer riding on the platform measures the angle θ that the thread supporting the light ball makes with the vertical. There is no friction anywhere. (a) How is θ related to the acceleration of the system? (b) If $m_1 = 250$ kg and $m_2 = 1250$ kg, what is θ ? (c) If you can vary m_1 and m_2 , what is the largest angle θ you could achieve? Explain how you need to adjust m_1 and m_2 to do this.

Figure P5.100

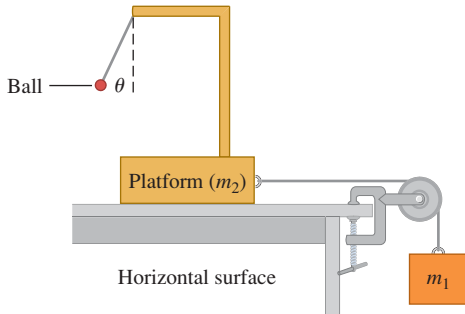

5.101 ••• Banked Curve I. A curve with a 120-m radius on a level road is banked at the correct angle for a speed of 20 m/s. If an automobile rounds this curve at 30 m/s, what is the minimum coefficient of static friction needed between tires and road to prevent skidding?

5.102 •• Banked Curve II. Consider a wet roadway banked as in Example 5.22 (Section 5.4), where there is a coefficient of static friction of 0.30 and a coefficient of kinetic friction of 0.25 between the tires and the roadway. The radius of the curve is $R = 50$ m. (a) If the banking angle is $\beta = 25^\circ$, what is the maximum speed the automobile can have before sliding up the banking? (b) What is the minimum speed the automobile can have before sliding down the banking?

5.103 ••• Blocks A, B, and C are placed as in Fig. P5.103 and connected by ropes of negligible mass. Both A and B weigh 25.0 N each, and the coefficient of kinetic friction between each block and the surface is 0.35. Block C descends with constant velocity. (a) Draw two separate free-body diagrams showing the forces acting on A and on B. (b) Find the tension in the rope connecting blocks A and B. (c) What is the weight of block C? (d) If the rope connecting A and B were cut, what would be the acceleration of C?

Figure P5.103

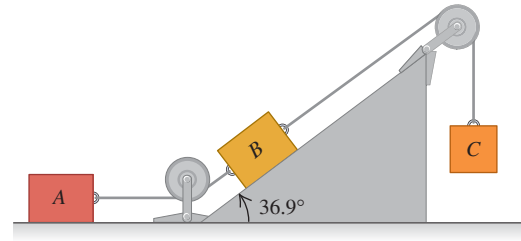

5.104 •• You are riding in a school bus. As the bus rounds a flat curve at constant speed, a lunch box with mass 0.500 kg, suspended from the ceiling of the bus by a string 1.80 m long, is found to hang at rest relative to the bus when the string makes an angle of 30.0° with the vertical. In this position the lunch box is 50.0 m from the center of curvature of the curve. What is the speed v of the bus?

5.105 • The Monkey and Bananas Problem.

A 20-kg monkey has a firm hold on a light rope that passes over a frictionless pulley and is attached to a 20-kg bunch of bananas (Fig. P5.105). The monkey looks up, sees the bananas, and starts to climb the rope to get them. (a) As the monkey climbs, do the bananas move up, down, or remain at rest? (b) As the monkey climbs, does the distance between the monkey and the bananas decrease, increase, or remain constant? (c) The monkey releases her hold on the rope. What happens to the distance between the monkey and the bananas while she is falling? (d) Before reaching the ground, the monkey grabs the rope to stop her fall. What do the bananas do?

Figure P5.105

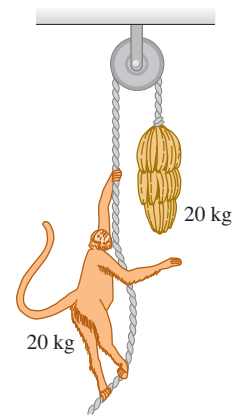

5.106 •• CALC You throw a rock downward into water with a speed of $3mg/k$, where k is the coefficient in Eq. (5.7). Assume that the relationship between fluid resistance and speed is as given in Eq. (5.7), and calculate the speed of the rock as a function of time.

5.107 •• A rock with mass $m = 3.00$ kg falls from rest in a viscous medium. The rock is acted on by a net constant downward force of 18.0 N (a combination of gravity and the buoyant force exerted by the medium) and by a fluid resistance force $f = kv$, where v is the speed in m/s and $k = 2.20$ N · s/m (see Section 5.3). (a) Find the initial acceleration a_0 . (b) Find the acceleration when the speed is 3.00 m/s. (c) Find the speed when the acceleration equals $0.1a_0$. (d) Find the terminal speed v_t . (e) Find the coordinate, speed, and acceleration 2.00 s after the start of the motion. (f) Find the time required to reach a speed of $0.9v_t$.

5.108 •• CALC A rock with mass m slides with initial velocity v_0 on a horizontal surface. A retarding force F_R that the surface exerts on the rock is proportional to the square root of the instantaneous velocity of the rock ($F_R = -kv^{1/2}$). (a) Find expressions for the velocity and position of the rock as a function of time. (b) In terms of m , k , and v_0 , at what time will the rock come to rest? (c) In terms of m , k , and v_0 , what is the distance of the rock from its starting point when it comes to rest?

5.109 ••• You observe a 1350-kg sports car rolling along flat pavement in a straight line. The only horizontal forces acting on it are a constant rolling friction and air resistance (proportional to the

square of its speed). You take the following data during a time interval of 25 s: When its speed is 32 m/s, the car slows down at a rate of -0.42 m/s^2 , and when its speed is decreased to 24 m/s, it slows down at -0.30 m/s^2 . (a) Find the coefficient of rolling friction and the air drag constant D . (b) At what constant speed will this car move down an incline that makes a 2.2° angle with the horizontal? (c) How is the constant speed for an incline of angle β related to the terminal speed of this sports car if the car drops off a high cliff? Assume that in both cases the air resistance force is proportional to the square of the speed, and the air drag constant is the same.

5.110 ••• The 4.00-kg block in Fig. P5.110 is attached to a vertical rod by means of two strings. When the system rotates about the axis of the rod, the strings are extended as shown in the diagram and the tension in the upper string is 80.0 N. (a) What is the tension in the lower cord? (b) How many revolutions per minute does the system make? (c) Find the number of revolutions per minute at which the lower cord just goes slack. (d) Explain what happens if the number of revolutions per minute is less than in part (c).

Figure P5.110

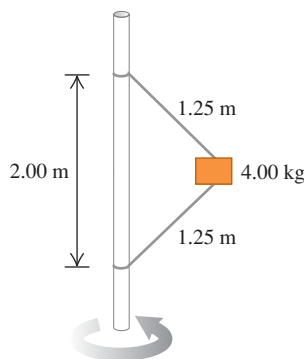

5.111 ••• **CALC** Equation (5.10) applies to the case where the initial velocity is zero. (a) Derive the corresponding equation for $v_y(t)$ when the falling object has an initial downward velocity with magnitude v_0 . (b) For the case where $v_0 < v_t$, sketch a graph of v_y as a function of t and label v_t on your graph. (c) Repeat part (b) for the case where $v_0 > v_t$. (d) Discuss what your result says about $v_y(t)$ when $v_0 = v_t$.

5.112 ••• **CALC** A small rock moves in water, and the force exerted on it by the water is given by Eq. (5.7). The terminal speed of the rock is measured and found to be 2.0 m/s. The rock is projected *upward* at an initial speed of 6.0 m/s. You can ignore the buoyancy force on the rock. (a) In the absence of fluid resistance, how high will the rock rise and how long will it take to reach this maximum height? (b) When the effects of fluid resistance are included, what are the answers to the questions in part (a)?

5.113 •• **Merry-Go-Round.** One December identical twins Jena and Jackie are playing on a large merry-go-round (a disk mounted parallel to the ground, on a vertical axle through its center) in their school playground in northern Minnesota. Each twin has mass 30.0 kg. The icy coating on the merry-go-round surface makes it frictionless. The merry-go-round revolves at a constant rate as the twins ride on it. Jena, sitting 1.80 m from the center of the merry-go-round, must hold on to one of the metal posts attached to the merry-go-round with a horizontal force of 60.0 N to keep from sliding off. Jackie is sitting at the edge, 3.60 m from the center. (a) With what horizontal force must Jackie hold on to keep from falling off? (b) If Jackie falls off, what will be her horizontal velocity when she becomes airborne?

5.114 •• A 70-kg person rides in a 30-kg cart moving at 12 m/s at the top of a hill that is in the shape of an arc of a circle with a radius of 40 m. (a) What is the apparent weight of the person as the cart passes over the top of the hill? (b) Determine the maximum speed that the cart may travel at the top of the hill without losing contact with the surface. Does your answer depend on the mass of the cart or the mass of the person? Explain.

5.115 •• On the ride “Spindletop” at the amusement park Six Flags Over Texas, people stood against the inner wall of a hollow vertical cylinder with radius 2.5 m. The cylinder started to rotate, and when it reached a constant rotation rate of 0.60 rev/s, the floor on which people were standing dropped about 0.5 m. The people remained pinned against the wall. (a) Draw a force diagram for a person on this ride, after the floor has dropped. (b) What minimum coefficient of static friction is required if the person on the ride is not to slide downward to the new position of the floor? (c) Does your answer in part (b) depend on the mass of the passenger? (*Note:* When the ride is over, the cylinder is slowly brought to rest. As it slows down, people slide down the walls to the floor.)

5.116 •• A passenger with mass 85 kg rides in a Ferris wheel like that in Example 5.23 (Section 5.4). The seats travel in a circle of radius 35 m. The Ferris wheel rotates at constant speed and makes one complete revolution every 25 s. Calculate the magnitude and direction of the net force exerted on the passenger by the seat when she is (a) one-quarter revolution past her lowest point and (b) one-quarter revolution past her highest point.

5.117 • **Uterior Motives.** You are driving a classic 1954 Nash Ambassador with a friend who is sitting to your right on the passenger side of the front seat. The Ambassador has flat bench seats. You would like to be closer to your friend and decide to use physics to achieve your romantic goal by making a quick turn. (a) Which way (to the left or to the right) should you turn the car to get your friend to slide closer to you? (b) If the coefficient of static friction between your friend and the car seat is 0.35, and you keep driving at a constant speed of 20 m/s, what is the maximum radius you could make your turn and still have your friend slide your way?

5.118 •• A physics major is working to pay his college tuition by performing in a traveling carnival. He rides a motorcycle inside a hollow, transparent plastic sphere. After gaining sufficient speed, he travels in a vertical circle with a radius of 13.0 m. The physics major has mass 70.0 kg, and his motorcycle has mass 40.0 kg. (a) What minimum speed must he have at the top of the circle if the tires of the motorcycle are not to lose contact with the sphere? (b) At the bottom of the circle, his speed is twice the value calculated in part (a). What is the magnitude of the normal force exerted on the motorcycle by the sphere at this point?

5.119 •• A small bead can slide without friction on a circular hoop that is in a vertical plane and has a radius of 0.100 m. The hoop rotates at a constant rate of 4.00 rev/s about a vertical diameter (Fig. P5.119). (a) Find the angle β at which the bead is in vertical equilibrium. (Of course, it has a radial acceleration toward the axis.) (b) Is it possible for the bead to “ride” at the same elevation as the center of the hoop? (c) What will happen if the hoop rotates at 1.00 rev/s?

Figure P5.119

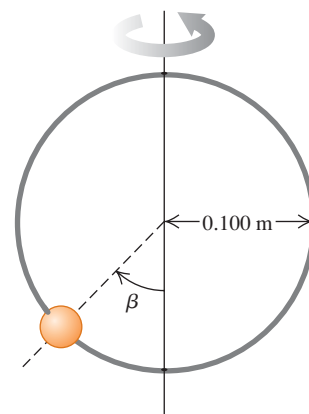

5.120 •• A small remote-controlled car with mass 1.60 kg moves at a constant speed of $v = 12.0 \text{ m/s}$ in a vertical circle inside a hollow metal cylinder that has a radius of 5.00 m (Fig. P5.120). What is the magnitude of the normal force exerted on the car by the walls of the cylinder at

(a) point A (at the bottom of the vertical circle) and (b) point B (at the top of the vertical circle)?

Figure P5.120

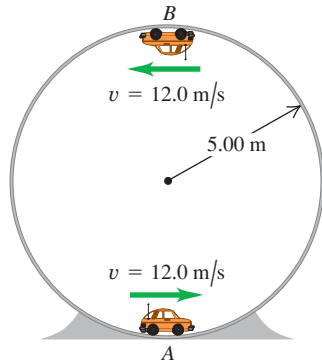

CHALLENGE PROBLEMS

5.121 ••• CALC Angle for Minimum Force. A box with weight w is pulled at constant speed along a level floor by a force \vec{F} that is at an angle θ above the horizontal. The coefficient of kinetic friction between the floor and box is μ_k . (a) In terms of θ , μ_k , and w , calculate F . (b) For $w = 400$ N and $\mu_k = 0.25$, calculate F for θ ranging from 0° to 90° in increments of 10° . Graph F versus θ . (c) From the general expression in part (a), calculate the value of θ for which the value of F , required to maintain constant speed, is a minimum. (*Hint:* At a point where a function is minimum, what are the first and second derivatives of the function? Here F is a function of θ .) For the special case of $w = 400$ N and $\mu_k = 0.25$, evaluate this optimal θ and compare your result to the graph you constructed in part (b).

5.122 ••• Moving Wedge. A wedge with mass M rests on a frictionless, horizontal tabletop. A block with mass m is placed on the wedge (Fig. P5.122a). There is no friction between the block and the wedge. The system is released from rest. (a) Calculate the acceleration of the wedge and the horizontal and vertical components of the acceleration of the block. (b) Do your answers to part (a) reduce to the correct results when M is very large? (c) As seen by a stationary observer, what is the shape of the trajectory of the block?

Figure P5.122

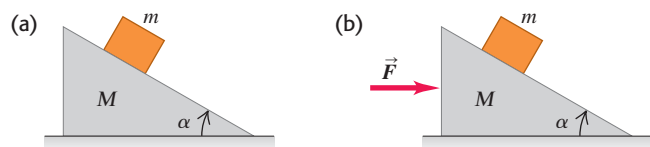

5.123 ••• A wedge with mass M rests on a frictionless horizontal tabletop. A block with mass m is placed on the wedge and a horizontal force \vec{F} is applied to the wedge (Fig. P5.122b). What must the magnitude of \vec{F} be if the block is to remain at a constant height above the tabletop?

5.124 ••• CALC Falling Baseball. You drop a baseball from the roof of a tall building. As the ball falls, the air exerts a drag force proportional to the square of the ball's speed ($f = Dv^2$). (a) In a diagram, show the direction of motion and indicate, with the aid of vectors, all the forces acting on the ball. (b) Apply Newton's second law and infer from the resulting equation the general properties of the motion. (c) Show that the ball acquires a terminal speed

that is as given in Eq. (5.13). (d) Derive the equation for the speed at any time. (*Note:*

$$\int \frac{dx}{a^2 - x^2} = \frac{1}{a} \operatorname{arctanh} \left(\frac{x}{a} \right)$$

where

$$\tanh(x) = \frac{e^x - e^{-x}}{e^x + e^{-x}} = \frac{e^{2x} - 1}{e^{2x} + 1}$$

defines the hyperbolic tangent.)

5.125 ••• Double Atwood's Machine.

In Fig. P5.125 masses m_1 and m_2 are connected by a light string A over a light, frictionless pulley B. The axle of pulley B is connected by a second light string C over a second light, frictionless pulley D to a mass m_3 . Pulley D is suspended from the ceiling by an attachment to its axle. The system is released from rest. In terms of m_1 , m_2 , m_3 , and g , what are (a) the acceleration of block m_3 ; (b) the acceleration of pulley B; (c) the acceleration of block m_1 ; (d) the acceleration of block m_2 ; (e) the tension in string A; (f) the tension in string C? (g) What do your expressions give for the special case of $m_1 = m_2$ and $m_3 = m_1 + m_2$? Is this sensible?

Figure P5.125

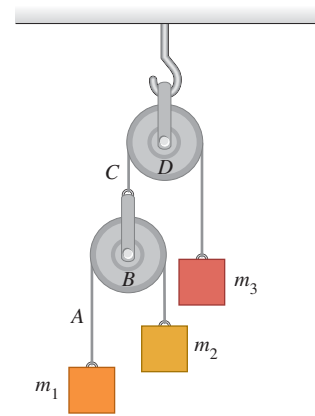

5.126 ••• The masses of blocks A and B in Fig. P5.126 are 20.0 kg and 10.0 kg, respectively. The blocks are initially at rest on the floor and are connected by a massless string passing over a massless and frictionless pulley. An upward force \vec{F} is applied to the pulley. Find the accelerations \vec{a}_A of block A and \vec{a}_B of block B when F is (a) 124 N; (b) 294 N; (c) 424 N.

Figure P5.126

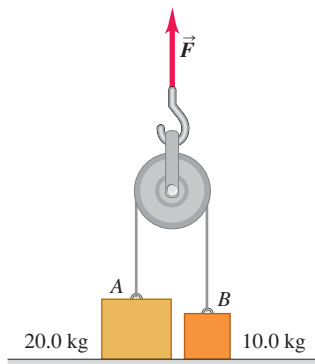

5.127 ••• A ball is held at rest at position A in Fig. P5.127 by two light strings. The horizontal string is cut and the ball starts swinging as a pendulum. Point B is the farthest to the right the ball goes as it swings back and forth. What is the ratio of the tension in the supporting string at position B to its value at A before the horizontal string was cut?

Figure P5.127

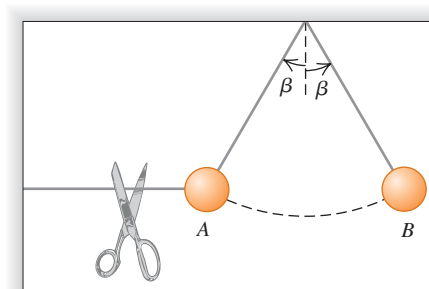

Answers

Chapter Opening Question ?

Neither; the upward force of the air has the *same* magnitude as the force of gravity. Although the skydiver and parachute are descending, their vertical velocity is constant and so their vertical acceleration is zero. Hence the net vertical force on the skydiver and parachute must also be zero, and the individual vertical forces must balance.

Test Your Understanding Questions

5.1 Answer: (ii) The two cables are arranged symmetrically, so the tension in either cable has the same magnitude T . The vertical component of the tension from each cable is $T \sin 45^\circ$ (or, equivalently, $T \cos 45^\circ$), so Newton's first law applied to the vertical forces tells us that $2T \sin 45^\circ - w = 0$. Hence $T = w / (2 \sin 45^\circ) = w / \sqrt{2} = 0.71w$. Each cable supports half of the weight of the traffic light, but the tension is greater than $w/2$ because only the vertical component of the tension counteracts the weight.

5.2 Answer: (ii) No matter what the instantaneous velocity of the glider, its acceleration is constant and has the value found in Example 5.12. In the same way, the acceleration of a body in free fall is the same whether it is ascending, descending, or at the high point of its motion (see Section 2.5).

5.3 Answers to (a): (i), (iii); answers to (b): (ii), (iv); answer to (c): (v) In situations (i) and (iii) the box is not accelerating (so the net force on it must be zero) and there is no other force acting parallel to the horizontal surface; hence no friction force is needed to prevent sliding. In situations (ii) and (iv) the box would start to slide over the surface if no friction were present, so a static friction force must act to prevent this. In situation (v) the box is sliding over a rough surface, so a kinetic friction force acts on it.

5.4 Answer: (iii) A satellite of mass m orbiting the earth at speed v in an orbit of radius r has an acceleration of magnitude v^2/r , so the net force acting on it from the earth's gravity has magnitude $F = mv^2/r$. The farther the satellite is from earth, the greater the value of r , the smaller the value of v , and hence the smaller the values of v^2/r and of F . In other words, the earth's gravitational force decreases with increasing distance.

Bridging Problem

Answers:

$$(a) T_{\max} = 2\pi \sqrt{\frac{h(\cos \beta + \mu_s \sin \beta)}{g \tan \beta (\sin \beta - \mu_s \cos \beta)}}$$

$$(b) T_{\min} = 2\pi \sqrt{\frac{h(\cos \beta - \mu_s \sin \beta)}{g \tan \beta (\sin \beta + \mu_s \cos \beta)}}$$