

Gauss's Law

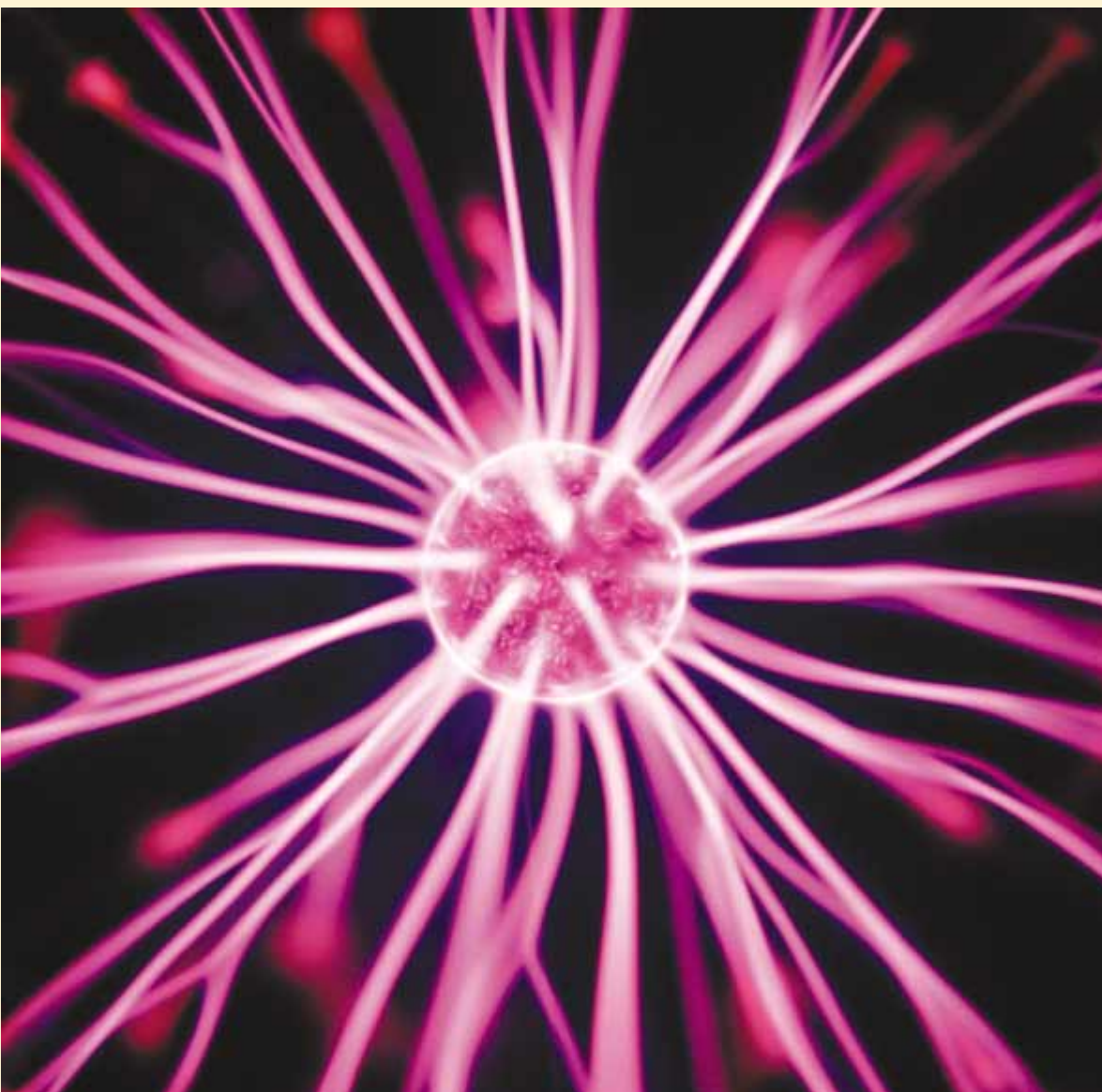

▲ In a table-top plasma ball, the colorful lines emanating from the sphere give evidence of strong electric fields. Using Gauss's law, we show in this chapter that the electric field surrounding a charged sphere is identical to that of a point charge. (Getty Images)

CHAPTER OUTLINE

- 24.1 Electric Flux
- 24.2 Gauss's Law
- 24.3 Application of Gauss's Law to Various Charge Distributions
- 24.4 Conductors in Electrostatic Equilibrium
- 24.5 Formal Derivation of Gauss's Law



In the preceding chapter we showed how to calculate the electric field generated by a given charge distribution. In this chapter, we describe *Gauss's law* and an alternative procedure for calculating electric fields. The law is based on the fact that the fundamental electrostatic force between point charges exhibits an inverse-square behavior. Although a consequence of Coulomb's law, Gauss's law is more convenient for calculating the electric fields of highly symmetric charge distributions and makes possible useful qualitative reasoning when dealing with complicated problems.

24.1 Electric Flux

The concept of electric field lines was described qualitatively in Chapter 23. We now treat electric field lines in a more quantitative way.

Consider an electric field that is uniform in both magnitude and direction, as shown in Figure 24.1. The field lines penetrate a rectangular surface of area A , whose plane is oriented perpendicular to the field. Recall from Section 23.6 that the number of lines per unit area (in other words, the *line density*) is proportional to the magnitude of the electric field. Therefore, the total number of lines penetrating the surface is proportional to the product EA . This product of the magnitude of the electric field E and surface area A perpendicular to the field is called the **electric flux** Φ_E (uppercase Greek phi):

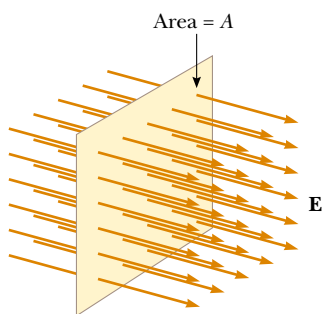

Figure 24.1 Field lines representing a uniform electric field penetrating a plane of area A perpendicular to the field. The electric flux Φ_E through this area is equal to EA .

$$\Phi_E = EA \quad (24.1)$$

From the SI units of E and A , we see that Φ_E has units of newton-meters squared per coulomb ($\text{N} \cdot \text{m}^2/\text{C}$.) **Electric flux is proportional to the number of electric field lines penetrating some surface.**

Example 24.1 Electric Flux Through a Sphere

What is the electric flux through a sphere that has a radius of 1.00 m and carries a charge of $+1.00 \mu\text{C}$ at its center?

Solution The magnitude of the electric field 1.00 m from this charge is found using Equation 23.9:

$$\begin{aligned} E &= k_e \frac{q}{r^2} = (8.99 \times 10^9 \text{ N} \cdot \text{m}^2/\text{C}^2) \frac{1.00 \times 10^{-6} \text{ C}}{(1.00 \text{ m})^2} \\ &= 8.99 \times 10^3 \text{ N/C} \end{aligned}$$

The field points radially outward and is therefore everywhere perpendicular to the surface of the sphere. The flux through the sphere (whose surface area $A = 4\pi r^2 = 12.6 \text{ m}^2$) is thus

$$\begin{aligned} \Phi_E &= EA = (8.99 \times 10^3 \text{ N/C})(12.6 \text{ m}^2) \\ &= 1.13 \times 10^5 \text{ N} \cdot \text{m}^2/\text{C} \end{aligned}$$

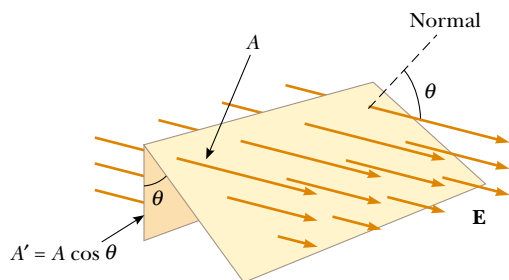

Figure 24.2 Field lines representing a uniform electric field penetrating an area A that is at an angle θ to the field. Because the number of lines that go through the area A' is the same as the number that go through A , the flux through A' is equal to the flux through A and is given by $\Phi_E = EA \cos \theta$.

If the surface under consideration is not perpendicular to the field, the flux through it must be less than that given by Equation 24.1. We can understand this by considering Figure 24.2, where the normal to the surface of area A is at an angle θ to the uniform electric field. Note that the number of lines that cross this area A is equal to the number that cross the area A' , which is a projection of area A onto a plane oriented perpendicular to the field. From Figure 24.2 we see that the two areas are related by $A' = A \cos \theta$. Because the flux through A equals the flux through A' , we conclude that the flux through A is

$$\Phi_E = EA' = EA \cos \theta \quad (24.2)$$

From this result, we see that the flux through a surface of fixed area A has a maximum value EA when the surface is perpendicular to the field (when the normal to the surface is parallel to the field, that is, $\theta = 0^\circ$ in Figure 24.2); the flux is zero when the surface is parallel to the field (when the normal to the surface is perpendicular to the field, that is, $\theta = 90^\circ$).

We assumed a uniform electric field in the preceding discussion. In more general situations, the electric field may vary over a surface. Therefore, our definition of flux given by Equation 24.2 has meaning only over a small element of area. Consider a general surface divided up into a large number of small elements, each of area ΔA . The variation in the electric field over one element can be neglected if the element is sufficiently small. It is convenient to define a vector $\Delta \mathbf{A}_i$ whose magnitude represents the area of the i th element of the surface and whose direction is defined to be *perpendicular* to the surface element, as shown in Figure 24.3. The electric field \mathbf{E}_i at the location of this element makes an angle θ_i with the vector $\Delta \mathbf{A}_i$. The electric flux $\Delta \Phi_E$ through this element is

$$\Delta \Phi_E = E_i \Delta A_i \cos \theta_i = \mathbf{E}_i \cdot \Delta \mathbf{A}_i$$

where we have used the definition of the scalar product (or dot product; see Chapter 7) of two vectors ($\mathbf{A} \cdot \mathbf{B} = AB \cos \theta$). By summing the contributions of all elements, we obtain the total flux through the surface. If we let the area of each element approach zero, then the number of elements approaches infinity and the sum is replaced by an integral. Therefore, the general definition of electric flux is¹

$$\Phi_E = \lim_{\Delta A_i \rightarrow 0} \sum \mathbf{E}_i \cdot \Delta \mathbf{A}_i = \int_{\text{surface}} \mathbf{E} \cdot d\mathbf{A} \quad (24.3)$$

Equation 24.3 is a *surface integral*, which means it must be evaluated over the surface in question. In general, the value of Φ_E depends both on the field pattern and on the surface.

¹ Drawings with field lines have their inaccuracies because a limited number of field lines are typically drawn in a diagram. Consequently, a small area element drawn on a diagram (depending on its location) may happen to have too few field lines penetrating it to represent the flux accurately. We stress that the basic definition of electric flux is Equation 24.3. The use of lines is only an aid for visualizing the concept.

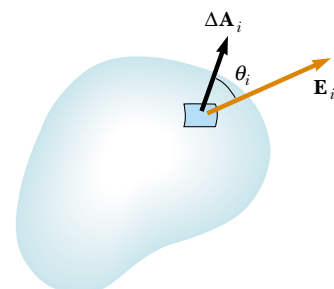

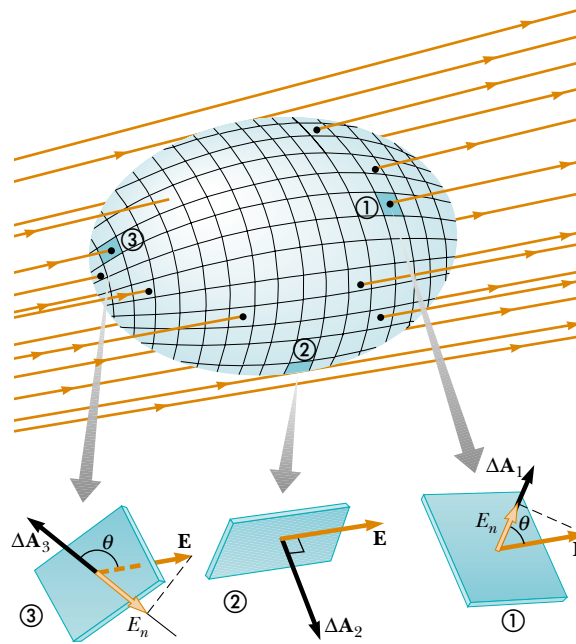

Figure 24.3 A small element of surface area ΔA_i . The electric field makes an angle θ_i with the vector $\Delta \mathbf{A}_i$, defined as being normal to the surface element, and the flux through the element is equal to $E_i \Delta A_i \cos \theta_i$.

Definition of electric flux

 At the Active Figures link at <http://www.pse6.com>, you can select any segment on the surface and see the relationship between the electric field vector \mathbf{E} and the area vector $\Delta\mathbf{A}_i$.



Active Figure 24.4 A closed surface in an electric field. The area vectors $\Delta\mathbf{A}_i$ are, by convention, normal to the surface and point outward. The flux through an area element can be positive (element ①), zero (element ②), or negative (element ③).

We are often interested in evaluating the flux through a *closed surface*, which is defined as one that divides space into an inside and an outside region, so that one cannot move from one region to the other without crossing the surface. The surface of a sphere, for example, is a closed surface.

Consider the closed surface in Figure 24.4. The vectors $\Delta\mathbf{A}_i$ point in different directions for the various surface elements, but at each point they are normal to the surface and, by convention, always point outward. At the element labeled ①, the field lines are crossing the surface from the inside to the outside and $\theta < 90^\circ$; hence, the flux $\Delta\Phi_E = \mathbf{E} \cdot \Delta\mathbf{A}_1$ through this element is positive. For element ②, the field lines graze the surface (perpendicular to the vector $\Delta\mathbf{A}_2$); thus, $\theta = 90^\circ$ and the flux is zero. For elements such as ③, where the field lines are crossing the surface from outside to inside, $180^\circ > \theta > 90^\circ$ and the flux is negative because $\cos \theta$ is negative. The *net* flux through the surface is proportional to the net number of lines leaving the surface, where the net number means *the number leaving the surface minus the number entering the surface*. If more lines are leaving than entering, the net flux is positive. If more lines are entering than leaving, the net flux is negative. Using the symbol \oint to represent an integral over a closed surface, we can write the net flux Φ_E through a closed surface as

$$\Phi_E = \oint \mathbf{E} \cdot d\mathbf{A} = \oint E_n dA \quad (24.4)$$

where E_n represents the component of the electric field normal to the surface. If the field is normal to the surface at each point and constant in magnitude, the calculation is straightforward, as it was in Example 24.1. Example 24.2 also illustrates this point.



Karl Friedrich Gauss

German mathematician and astronomer (1777–1855)

Gauss received a doctoral degree in mathematics from the University of Helmstedt in 1799. In addition to his work in electromagnetism, he made contributions to mathematics and science in number theory, statistics, non-Euclidean geometry, and cometary orbital mechanics. He was a founder of the German Magnetic Union, which studies the Earth's magnetic field on a continual basis.

Quick Quiz 24.1 Suppose the radius of the sphere in Example 24.1 is changed to 0.500 m. What happens to the flux through the sphere and the magnitude of the electric field at the surface of the sphere? (a) The flux and field both increase. (b) The flux and field both decrease. (c) The flux increases and the field decreases. (d) The flux decreases and the field increases. (e) The flux remains the same and the field increases. (f) The flux decreases and the field remains the same.

Quick Quiz 24.2 In a charge-free region of space, a closed container is placed in an electric field. A requirement for the total electric flux through the surface of the container to be zero is that (a) the field must be uniform, (b) the container must be symmetric, (c) the container must be oriented in a certain way, or (d) the requirement does not exist—the total electric flux is zero no matter what.

Example 24.2 Flux Through a Cube

Consider a uniform electric field \mathbf{E} oriented in the x direction. Find the net electric flux through the surface of a cube of edge length ℓ , oriented as shown in Figure 24.5.

Solution The net flux is the sum of the fluxes through all faces of the cube. First, note that the flux through four of

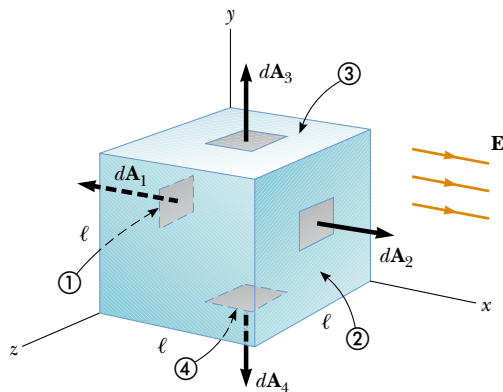

Figure 24.5 (Example 24.2) A closed surface in the shape of a cube in a uniform electric field oriented parallel to the x axis. Side ④ is the bottom of the cube, and side ① is opposite side ②.

the faces (③, ④, and the unnumbered ones) is zero because \mathbf{E} is perpendicular to $d\mathbf{A}$ on these faces.

The net flux through faces ① and ② is

$$\Phi_E = \int_1 \mathbf{E} \cdot d\mathbf{A} + \int_2 \mathbf{E} \cdot d\mathbf{A}$$

For face ①, \mathbf{E} is constant and directed inward but $d\mathbf{A}_1$ is directed outward ($\theta = 180^\circ$); thus, the flux through this face is

$$\int_1 \mathbf{E} \cdot d\mathbf{A} = \int_1 E(\cos 180^\circ) dA = -E \int_1 dA = -EA = -E\ell^2$$

because the area of each face is $A = \ell^2$.

For face ②, \mathbf{E} is constant and outward and in the same direction as $d\mathbf{A}_2$ ($\theta = 0^\circ$); hence, the flux through this face is

$$\int_2 \mathbf{E} \cdot d\mathbf{A} = \int_2 E(\cos 0^\circ) dA = E \int_2 dA = +EA = E\ell^2$$

Therefore, the net flux over all six faces is

$$\Phi_E = -E\ell^2 + E\ell^2 + 0 + 0 + 0 + 0 = 0$$

24.2 Gauss's Law

In this section we describe a general relationship between the net electric flux through a closed surface (often called a *Gaussian surface*) and the charge enclosed by the surface. This relationship, known as *Gauss's law*, is of fundamental importance in the study of electric fields.

Let us again consider a positive point charge q located at the center of a sphere of radius r , as shown in Figure 24.6. From Equation 23.9 we know that the magnitude of the electric field everywhere on the surface of the sphere is $E = k_e q/r^2$. As noted in Example 24.1, the field lines are directed radially outward and hence are perpendicular to the surface at every point on the surface. That is, at each surface point, \mathbf{E} is parallel to the vector $\Delta\mathbf{A}_i$ representing a local element of area ΔA_i surrounding the surface point. Therefore,

$$\mathbf{E} \cdot \Delta\mathbf{A}_i = E \Delta A_i$$

and from Equation 24.4 we find that the net flux through the gaussian surface is

$$\Phi_E = \oint \mathbf{E} \cdot d\mathbf{A} = \oint E dA = E \oint dA$$

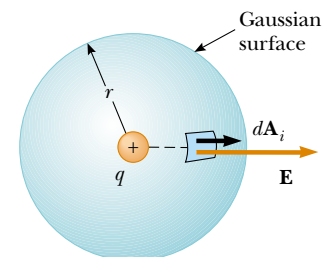

Figure 24.6 A spherical gaussian surface of radius r surrounding a point charge q . When the charge is at the center of the sphere, the electric field is everywhere normal to the surface and constant in magnitude.

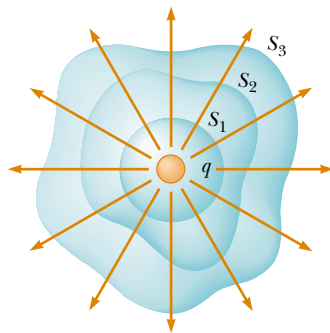

Figure 24.7 Closed surfaces of various shapes surrounding a charge q . The net electric flux is the same through all surfaces.

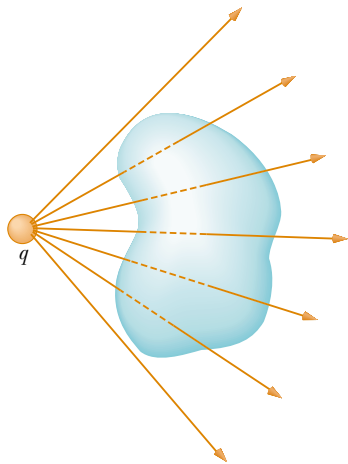
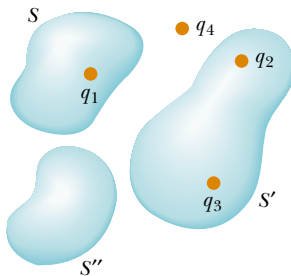



Figure 24.8 A point charge located *outside* a closed surface. The number of lines entering the surface equals the number leaving the surface.



Active Figure 24.9 The net electric flux through any closed surface depends only on the charge *inside* that surface. The net flux through surface S is q_1/ϵ_0 , the net flux through surface S' is $(q_2 + q_3)/\epsilon_0$, and the net flux through surface S'' is zero. Charge q_4 does not contribute to the flux through any surface because it is outside all surfaces.

 **At the Active Figures link at <http://www.pse6.com>, you can change the size and shape of a closed surface and see the effect on the electric flux of surrounding combinations of charge with that surface.**

where we have moved E outside of the integral because, by symmetry, E is constant over the surface and given by $E = k_e q/r^2$. Furthermore, because the surface is spherical, $\oint dA = A = 4\pi r^2$. Hence, the net flux through the gaussian surface is

$$\Phi_E = \frac{k_e q}{r^2} (4\pi r^2) = 4\pi k_e q$$

Recalling from Section 23.3 that $k_e = 1/4\pi\epsilon_0$, we can write this equation in the form

$$\Phi_E = \frac{q}{\epsilon_0} \quad (24.5)$$

We can verify that this expression for the net flux gives the same result as Example 24.1: $\Phi_E = (1.00 \times 10^{-6} \text{ C}) / (8.85 \times 10^{-12} \text{ C}^2/\text{N} \cdot \text{m}^2) = 1.13 \times 10^5 \text{ N} \cdot \text{m}^2/\text{C}$.

Note from Equation 24.5 that the net flux through the spherical surface is proportional to the charge inside. The flux is independent of the radius r because the area of the spherical surface is proportional to r^2 , whereas the electric field is proportional to $1/r^2$. Thus, in the product of area and electric field, the dependence on r cancels.

Now consider several closed surfaces surrounding a charge q , as shown in Figure 24.7. Surface S_1 is spherical, but surfaces S_2 and S_3 are not. From Equation 24.5, the flux that passes through S_1 has the value q/ϵ_0 . As we discussed in the preceding section, flux is proportional to the number of electric field lines passing through a surface. The construction shown in Figure 24.7 shows that the number of lines through S_1 is equal to the number of lines through the nonspherical surfaces S_2 and S_3 . Therefore, we conclude that **the net flux through any closed surface surrounding a point charge q is given by q/ϵ_0 and is independent of the shape of that surface.**

Now consider a point charge located *outside* a closed surface of arbitrary shape, as shown in Figure 24.8. As you can see from this construction, any electric field line that enters the surface leaves the surface at another point. The number of electric field lines entering the surface equals the number leaving the surface. Therefore, we conclude that **the net electric flux through a closed surface that surrounds no charge is zero.** If we apply this result to Example 24.2, we can easily see that the net flux through the cube is zero because there is no charge inside the cube.

Let us extend these arguments to two generalized cases: (1) that of many point charges and (2) that of a continuous distribution of charge. We once again use the superposition principle, which states that **the electric field due to many charges is the vector sum of the electric fields produced by the individual charges.** Therefore, we can express the flux through any closed surface as

$$\oint \mathbf{E} \cdot d\mathbf{A} = \oint (\mathbf{E}_1 + \mathbf{E}_2 + \cdots) \cdot d\mathbf{A}$$

where \mathbf{E} is the total electric field at any point on the surface produced by the vector addition of the electric fields at that point due to the individual charges. Consider the system of charges shown in Figure 24.9. The surface S surrounds only one charge, q_1 ; hence, the net flux through S is q_1/ϵ_0 . The flux through S due to charges q_2 , q_3 , and q_4 outside it is zero because each electric field line that enters S at one point leaves it at

another. The surface S' surrounds charges q_2 and q_3 ; hence, the net flux through it is $(q_2 + q_3)/\epsilon_0$. Finally, the net flux through surface S'' is zero because there is no charge inside this surface. That is, *all* the electric field lines that enter S'' at one point leave at another. Notice that charge q_4 does not contribute to the net flux through any of the surfaces because it is outside all of the surfaces.

Gauss's law, which is a generalization of what we have just described, states that the net flux through *any* closed surface is

$$\Phi_E = \oint \mathbf{E} \cdot d\mathbf{A} = \frac{q_{\text{in}}}{\epsilon_0} \quad (24.6)$$

Gauss's law

where q_{in} represents the net charge inside the surface and \mathbf{E} represents the electric field at any point on the surface.

A formal proof of Gauss's law is presented in Section 24.5. When using Equation 24.6, you should note that although the charge q_{in} is the net charge inside the gaussian surface, \mathbf{E} represents the *total electric field*, which includes contributions from charges both inside and outside the surface.

In principle, Gauss's law can be solved for \mathbf{E} to determine the electric field due to a system of charges or a continuous distribution of charge. In practice, however, this type of solution is applicable only in a limited number of highly symmetric situations. In the next section we use Gauss's law to evaluate the electric field for charge distributions that have spherical, cylindrical, or planar symmetry. If one chooses the gaussian surface surrounding the charge distribution carefully, the integral in Equation 24.6 can be simplified.

Quick Quiz 24.3 If the net flux through a gaussian surface is *zero*, the following four statements *could be true*. Which of the statements *must be true*? (a) There are no charges inside the surface. (b) The net charge inside the surface is zero. (c) The electric field is zero everywhere on the surface. (d) The number of electric field lines entering the surface equals the number leaving the surface.

Quick Quiz 24.4 Consider the charge distribution shown in Figure 24.9. The charges contributing to the total electric *flux* through surface S' are (a) q_1 only (b) q_4 only (c) q_2 and q_3 (d) all four charges (e) none of the charges.

Quick Quiz 24.5 Again consider the charge distribution shown in Figure 24.9. The charges contributing to the total electric *field* at a chosen point on the surface S' are (a) q_1 only (b) q_4 only (c) q_2 and q_3 (d) all four charges (e) none of the charges.

▲ PITFALL PREVENTION

24.1 Zero Flux is not Zero Field

We see two situations in which there is zero flux through a closed surface—either there are no charged particles enclosed by the surface or there are charged particles enclosed, but the net charge inside the surface is zero. For either situation, it is *incorrect* to conclude that the electric field on the surface is zero. Gauss's law states that the electric *flux* is proportional to the enclosed charge, not the electric *field*.

Conceptual Example 24.3 Flux Due to a Point Charge

A spherical gaussian surface surrounds a point charge q . Describe what happens to the total flux through the surface if

- (A) the charge is tripled,
- (B) the radius of the sphere is doubled,
- (C) the surface is changed to a cube, and
- (D) the charge is moved to another location inside the surface.

Solution

(A) The flux through the surface is tripled because flux is proportional to the amount of charge inside the surface.

(B) The flux does not change because all electric field lines from the charge pass through the sphere, regardless of its radius.

(C) The flux does not change when the shape of the gaussian surface changes because all electric field lines from the charge pass through the surface, regardless of its shape.

(D) The flux does not change when the charge is moved to another location inside that surface because Gauss's law refers to the total charge enclosed, regardless of where the charge is located inside the surface.

24.3 Application of Gauss's Law to Various Charge Distributions

As mentioned earlier, Gauss's law is useful in determining electric fields when the charge distribution is characterized by a high degree of symmetry. The following examples demonstrate ways of choosing the gaussian surface over which the surface integral given by Equation 24.6 can be simplified and the electric field determined. In choosing the surface, we should always take advantage of the symmetry of the charge distribution so that we can remove E from the integral and solve for it. The goal in this type of calculation is to determine a surface that satisfies one or more of the following conditions:

PITFALL PREVENTION

24.2 Gaussian Surfaces are not Real

A gaussian surface is an imaginary surface that you choose to satisfy the conditions listed here. It does not have to coincide with a physical surface in the situation.

1. The value of the electric field can be argued by symmetry to be constant over the surface.
2. The dot product in Equation 24.6 can be expressed as a simple algebraic product $E dA$ because \mathbf{E} and $d\mathbf{A}$ are parallel.
3. The dot product in Equation 24.6 is zero because \mathbf{E} and $d\mathbf{A}$ are perpendicular.
4. The field can be argued to be zero over the surface.

All four of these conditions are used in examples throughout the remainder of this chapter.

Example 24.4 The Electric Field Due to a Point Charge

Starting with Gauss's law, calculate the electric field due to an isolated point charge q .

Solution A single charge represents the simplest possible charge distribution, and we use this familiar case to show how to solve for the electric field with Gauss's law. Figure 24.10 and our discussion of the electric field due to a point charge in Chapter 23 help us to conceptualize the physical situation. Because the space around the single charge has spherical symmetry, we categorize this problem as one in which there is enough symmetry to apply Gauss's law. To analyze any Gauss's law problem, we consider the details of the electric field and choose a gaussian surface that satisfies some or all of the conditions that we have listed above. We choose a spherical gaussian surface of radius r centered on the point charge, as shown in Figure 24.10. The electric field due to a positive point charge is directed radially outward by

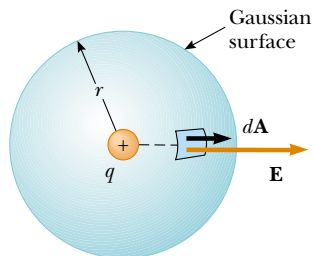

Figure 24.10 (Example 24.4) The point charge q is at the center of the spherical gaussian surface, and \mathbf{E} is parallel to $d\mathbf{A}$ at every point on the surface.

symmetry and is therefore normal to the surface at every point. Thus, as in condition (2), \mathbf{E} is parallel to $d\mathbf{A}$ at each point. Therefore, $\mathbf{E} \cdot d\mathbf{A} = E dA$ and Gauss's law gives

$$\Phi_E = \oint \mathbf{E} \cdot d\mathbf{A} = \oint E dA = \frac{q}{\epsilon_0}$$

By symmetry, E is constant everywhere on the surface, which satisfies condition (1), so it can be removed from the integral. Therefore,

$$\oint E dA = E \oint dA = E(4\pi r^2) = \frac{q}{\epsilon_0}$$

where we have used the fact that the surface area of a sphere is $4\pi r^2$. Now, we solve for the electric field:

$$E = \frac{q}{4\pi\epsilon_0 r^2} = k_e \frac{q}{r^2}$$

To finalize this problem, note that this is the familiar electric field due to a point charge that we developed from Coulomb's law in Chapter 23.

What If? What if the charge in Figure 24.10 were not at the center of the spherical gaussian surface?

Answer In this case, while Gauss's law would still be valid, the situation would not possess enough symmetry to evaluate the electric field. Because the charge is not at the center, the magnitude of \mathbf{E} would vary over the surface of the sphere and the vector \mathbf{E} would not be everywhere perpendicular to the surface.

Example 24.5 A Spherically Symmetric Charge Distribution**Interactive**

An insulating solid sphere of radius a has a uniform volume charge density ρ and carries a total positive charge Q (Fig. 24.11).

(A) Calculate the magnitude of the electric field at a point outside the sphere.

Solution Because the charge distribution is spherically symmetric, we again select a spherical gaussian surface of radius r , concentric with the sphere, as shown in Figure 24.11a. For this choice, conditions (1) and (2) are satisfied, as they were for the point charge in Example 24.4. Following the line of reasoning given in Example 24.4, we find that

$$(1) \quad E = k_e \frac{Q}{r^2} \quad (\text{for } r > a)$$

Note that this result is identical to the one we obtained for a point charge. Therefore, we conclude that, **for a uniformly charged sphere, the field in the region external to the sphere is equivalent to that of a point charge located at the center of the sphere.**

(B) Find the magnitude of the electric field at a point inside the sphere.

Solution In this case we select a spherical gaussian surface having radius $r < a$, concentric with the insulating sphere (Fig. 24.11b). Let us denote the volume of this smaller sphere by V' . To apply Gauss's law in this situation, it is important to recognize that the charge q_{in} within the gaussian surface of volume V' is less than Q . To calculate q_{in} , we use the fact that $q_{\text{in}} = \rho V'$:

$$q_{\text{in}} = \rho V' = \rho \left(\frac{4}{3} \pi r^3 \right)$$

By symmetry, the magnitude of the electric field is constant everywhere on the spherical gaussian surface and is normal to the surface at each point—both conditions

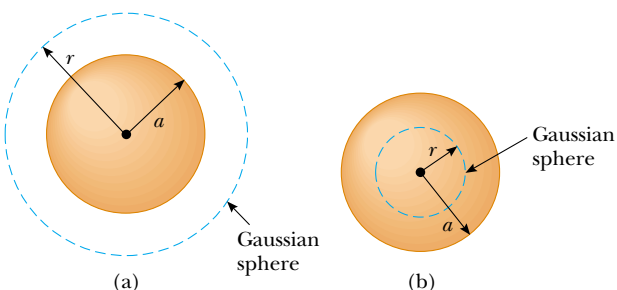

Figure 24.11 (Example 24.5) A uniformly charged insulating sphere of radius a and total charge Q . (a) For points outside the sphere, a large spherical gaussian surface is drawn concentric with the sphere. In diagrams such as this, the dotted line represents the intersection of the gaussian surface with the plane of the page. (b) For points inside the sphere, a spherical gaussian surface smaller than the sphere is drawn.

(1) and (2) are satisfied. Therefore, Gauss's law in the region $r < a$ gives

$$\oint E dA = E \oint dA = E (4\pi r^2) = \frac{q_{\text{in}}}{\epsilon_0}$$

Solving for E gives

$$E = \frac{q_{\text{in}}}{4\pi\epsilon_0 r^2} = \frac{\rho \left(\frac{4}{3} \pi r^3 \right)}{4\pi\epsilon_0 r^2} = \frac{\rho}{3\epsilon_0} r$$

Because $\rho = Q / \left(\frac{4}{3} \pi a^3 \right)$ by definition and because $k_e = 1/4\pi\epsilon_0$, this expression for E can be written as

$$(2) \quad E = \frac{Qr}{4\pi\epsilon_0 a^3} = k_e \frac{Q}{a^3} r \quad (\text{for } r < a)$$

Note that this result for E differs from the one we obtained in part (A). It shows that $E \rightarrow 0$ as $r \rightarrow 0$. Therefore, the result eliminates the problem that would exist at $r = 0$ if E varied as $1/r^2$ inside the sphere as it does outside the sphere. That is, if $E \propto 1/r^2$ for $r < a$, the field would be infinite at $r = 0$, which is physically impossible.

What If? Suppose we approach the radial position $r = a$ from inside the sphere and from outside. Do we measure the same value of the electric field from both directions?

Answer From Equation (1), we see that the field approaches a value from the outside given by

$$E = \lim_{r \rightarrow a} \left(k_e \frac{Q}{r^2} \right) = k_e \frac{Q}{a^2}$$

From the inside, Equation (2) gives us

$$E = \lim_{r \rightarrow a} \left(k_e \frac{Q}{a^3} r \right) = k_e \frac{Q}{a^3} a = k_e \frac{Q}{a^2}$$

Thus, the value of the field is the same as we approach the surface from both directions. A plot of E versus r is shown in Figure 24.12. Note that the magnitude of the field is continuous, but the derivative of the field magnitude is not.

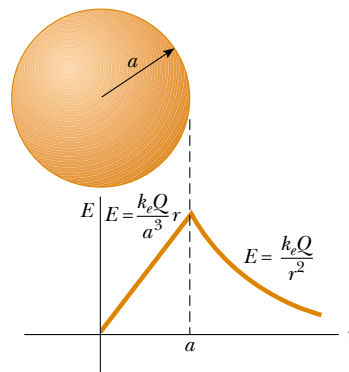

Figure 24.12 (Example 24.5) A plot of E versus r for a uniformly charged insulating sphere. The electric field inside the sphere ($r < a$) varies linearly with r . The field outside the sphere ($r > a$) is the same as that of a point charge Q located at $r = 0$.



At the Interactive Worked Example link at <http://www.pse6.com>, you can investigate the electric field inside and outside the sphere.

Example 24.6 The Electric Field Due to a Thin Spherical Shell

A thin spherical shell of radius a has a total charge Q distributed uniformly over its surface (Fig. 24.13a). Find the electric field at points

(A) outside and

(B) inside the shell.

Solution

(A) The calculation for the field outside the shell is identical to that for the solid sphere shown in Example 24.5a. If we construct a spherical gaussian surface of radius $r > a$ concentric with the shell (Fig. 24.13b), the charge inside this surface is Q . Therefore, the field at a point outside the shell is equivalent to that due to a point charge Q located at the center:

$$E = k_e \frac{Q}{r^2} \quad (\text{for } r > a)$$

(B) The electric field inside the spherical shell is zero. This follows from Gauss's law applied to a spherical surface of radius $r < a$ concentric with the shell (Fig. 24.13c). Because of the spherical symmetry of the charge distribution and because the net charge inside the surface is zero—satisfaction of conditions (1) and (2) again—application of Gauss's law shows that $E = 0$ in the region $r < a$. We obtain the same results using Equation 23.11 and integrating over the charge distribution. This calculation is rather complicated. Gauss's law allows us to determine these results in a much simpler way.

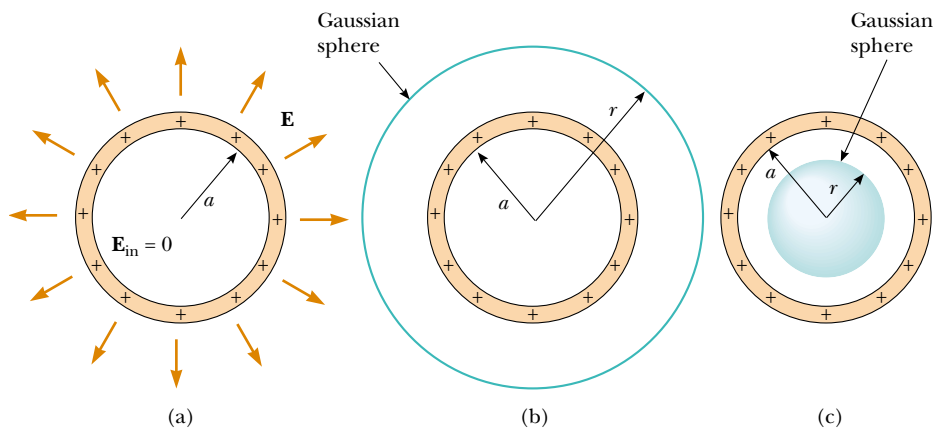

Figure 24.13 (Example 24.6) (a) The electric field inside a uniformly charged spherical shell is zero. The field outside is the same as that due to a point charge Q located at the center of the shell. (b) Gaussian surface for $r > a$. (c) Gaussian surface for $r < a$.

Example 24.7 A Cylindrically Symmetric Charge Distribution

Find the electric field a distance r from a line of positive charge of infinite length and constant charge per unit length λ (Fig. 24.14a).

Solution The symmetry of the charge distribution requires that \mathbf{E} be perpendicular to the line charge and directed outward, as shown in Figure 24.14a and b. To reflect the symmetry of the charge distribution, we select a cylindrical gaussian surface of radius r and length ℓ that is coaxial with the line charge. For the curved part of this surface, \mathbf{E} is constant in magnitude and perpendicular to the surface at each point—satisfaction of conditions (1) and (2). Furthermore, the flux through the ends of the gaussian cylinder is zero because \mathbf{E} is parallel to these surfaces—the first application we have seen of condition (3).

We take the surface integral in Gauss's law over the entire gaussian surface. Because of the zero value of $\mathbf{E} \cdot d\mathbf{A}$ for the ends of the cylinder, however, we can restrict our attention to only the curved surface of the cylinder.

The total charge inside our gaussian surface is $\lambda\ell$. Applying Gauss's law and conditions (1) and (2), we find that for the curved surface

$$\Phi_E = \oint \mathbf{E} \cdot d\mathbf{A} = E \oint dA = EA = \frac{q_{\text{in}}}{\epsilon_0} = \frac{\lambda\ell}{\epsilon_0}$$

The area of the curved surface is $A = 2\pi r\ell$; therefore,

$$E(2\pi r\ell) = \frac{\lambda\ell}{\epsilon_0}$$

$$E = \frac{\lambda}{2\pi\epsilon_0 r} = 2k_e \frac{\lambda}{r} \quad (24.7)$$

Thus, we see that the electric field due to a cylindrically symmetric charge distribution varies as $1/r$, whereas the field external to a spherically symmetric charge distribution varies as $1/r^2$. Equation 24.7 was also derived by integration of the field of a point charge. (See Problem 35 in Chapter 23.)

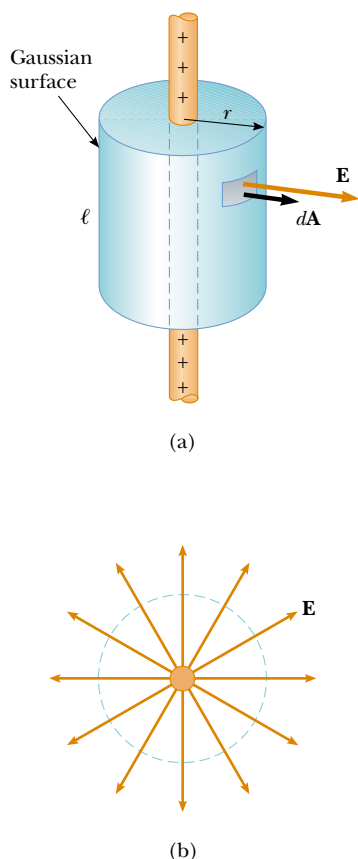

What If? What if the line segment in this example were not infinitely long?

Answer If the line charge in this example were of finite length, the result for E would not be that given by Equation 24.7. A finite line charge does not possess sufficient symmetry for us to make use of Gauss's law. This is because the magnitude of the electric field is no longer constant over the surface of the gaussian cylinder—the field near the ends of the line would be different from that far from the ends. Thus, condition (1) would not be satisfied in this situation. Furthermore, \mathbf{E} is not perpendicular to the cylindrical surface at all points—the field vectors near the ends would have a component parallel to the line. Thus, condition (2) would not be satisfied. For points close to a finite line charge and far from the ends, Equation 24.7 gives a good approximation of the value of the field.

It is left for you to show (see Problem 29) that the electric field inside a uniformly charged rod of finite radius and infinite length is proportional to r .

Figure 24.14 (Example 24.7) (a) An infinite line of charge surrounded by a cylindrical gaussian surface concentric with the line. (b) An end view shows that the electric field at the cylindrical surface is constant in magnitude and perpendicular to the surface.

Example 24.8 A Plane of Charge

Find the electric field due to an infinite plane of positive charge with uniform surface charge density σ .

Solution By symmetry, \mathbf{E} must be perpendicular to the plane and must have the same magnitude at all points equidistant from the plane. The fact that the direction of \mathbf{E} is away from positive charges indicates that the direction of \mathbf{E} on one side of the plane must be opposite its direction on the other side, as shown in Figure 24.15. A gaussian surface that reflects the symmetry is a small cylinder whose axis is perpendicular to the plane and whose ends

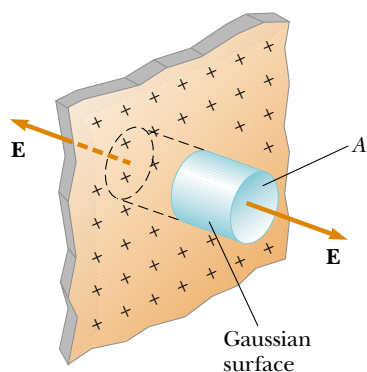

Figure 24.15 (Example 24.8) A cylindrical gaussian surface penetrating an infinite plane of charge. The flux is EA through each end of the gaussian surface and zero through its curved surface.

each have an area A and are equidistant from the plane. Because \mathbf{E} is parallel to the curved surface—and, therefore, perpendicular to $d\mathbf{A}$ everywhere on the surface—condition (3) is satisfied and there is no contribution to the surface integral from this surface. For the flat ends of the cylinder, conditions (1) and (2) are satisfied. The flux through each end of the cylinder is EA ; hence, the total flux through the entire gaussian surface is just that through the ends, $\Phi_E = 2EA$.

Noting that the total charge inside the surface is $q_{\text{in}} = \sigma A$, we use Gauss's law and find that the total flux through the gaussian surface is

$$\Phi_E = 2EA = \frac{q_{\text{in}}}{\epsilon_0} = \frac{\sigma A}{\epsilon_0}$$

leading to

$$E = \frac{\sigma}{2\epsilon_0} \quad (24.8)$$

Because the distance from each flat end of the cylinder to the plane does not appear in Equation 24.8, we conclude that $E = \sigma/2\epsilon_0$ at *any* distance from the plane. That is, the field is uniform everywhere.

What If? Suppose we place two infinite planes of charge parallel to each other, one positively charged and the other negatively charged. Both planes have the same surface charge density. What does the electric field look like now?

Answer In this situation, the electric fields due to the two planes add in the region between the planes, resulting in a uniform field of magnitude σ/ϵ_0 , and cancel elsewhere to

give a field of zero. This is a practical way to achieve uniform electric fields, such as those needed in the CRT tube discussed in Section 23.7.

Conceptual Example 24.9 Don't Use Gauss's Law Here!

Explain why Gauss's law cannot be used to calculate the electric field near an electric dipole, a charged disk, or a triangle with a point charge at each corner.

Solution The charge distributions of all these configurations do not have sufficient symmetry to make the use of

Gauss's law practical. We cannot find a closed surface surrounding any of these distributions that satisfies one or more of conditions (1) through (4) listed at the beginning of this section.

24.4 Conductors in Electrostatic Equilibrium

As we learned in Section 23.2, a good electrical conductor contains charges (electrons) that are not bound to any atom and therefore are free to move about within the material. When there is no net motion of charge within a conductor, the conductor is in **electrostatic equilibrium**. A conductor in electrostatic equilibrium has the following properties:

1. The electric field is zero everywhere inside the conductor.
2. If an isolated conductor carries a charge, the charge resides on its surface.
3. The electric field just outside a charged conductor is perpendicular to the surface of the conductor and has a magnitude σ/ϵ_0 , where σ is the surface charge density at that point.
4. On an irregularly shaped conductor, the surface charge density is greatest at locations where the radius of curvature of the surface is smallest.

We verify the first three properties in the discussion that follows. The fourth property is presented here so that we have a complete list of properties for conductors in electrostatic equilibrium, but cannot be verified until Chapter 25.

We can understand the first property by considering a conducting slab placed in an external field \mathbf{E} (Fig. 24.16). The electric field inside the conductor *must* be zero under the assumption that we have electrostatic equilibrium. If the field were not zero, free electrons in the conductor would experience an electric force ($\mathbf{F} = q\mathbf{E}$) and would accelerate due to this force. This motion of electrons, however, would mean that the conductor is not in electrostatic equilibrium. Thus, the existence of electrostatic equilibrium is consistent only with a zero field in the conductor.

Let us investigate how this zero field is accomplished. Before the external field is applied, free electrons are uniformly distributed throughout the conductor. When the external field is applied, the free electrons accelerate to the left in Figure 24.16, causing a plane of negative charge to be present on the left surface. The movement of electrons to the left results in a plane of positive charge on the right surface. These planes of charge create an additional electric field inside the conductor that opposes the external field. As the electrons move, the surface charge densities on the left and right surfaces increase until the magnitude of the internal field equals that of the external field, resulting in a net field of zero inside the conductor. The time it takes a good conductor to reach equilibrium is on the order of 10^{-16} s, which for most purposes can be considered instantaneous.

Properties of a conductor in electrostatic equilibrium

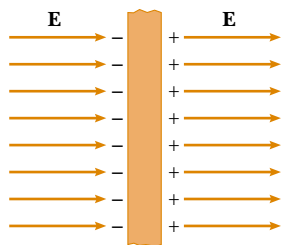

Figure 24.16 A conducting slab in an external electric field \mathbf{E} . The charges induced on the two surfaces of the slab produce an electric field that opposes the external field, giving a resultant field of zero inside the slab.

We can use Gauss's law to verify the second property of a conductor in electrostatic equilibrium. Figure 24.17 shows an arbitrarily shaped conductor. A gaussian surface is drawn inside the conductor and can be as close to the conductor's surface as we wish. As we have just shown, the electric field everywhere inside the conductor is zero when it is in electrostatic equilibrium. Therefore, the electric field must be zero at every point on the gaussian surface, in accordance with condition (4) in Section 24.3. Thus, the net flux through this gaussian surface is zero. From this result and Gauss's law, we conclude that the net charge inside the gaussian surface is zero. Because there can be no net charge inside the gaussian surface (which is arbitrarily close to the conductor's surface), **any net charge on the conductor must reside on its surface.** Gauss's law does not indicate how this excess charge is distributed on the conductor's surface, only that it resides exclusively on the surface.

We can also use Gauss's law to verify the third property. First, note that if the field vector \mathbf{E} had a component parallel to the conductor's surface, free electrons would experience an electric force and move along the surface; in such a case, the conductor would not be in equilibrium. Thus, the field vector must be perpendicular to the surface. To determine the magnitude of the electric field, we draw a gaussian surface in the shape of a small cylinder whose end faces are parallel to the surface of the conductor (Fig. 24.18). Part of the cylinder is just outside the conductor, and part is inside. The field is perpendicular to the conductor's surface from the condition of electrostatic equilibrium. Thus, we satisfy condition (3) in Section 24.3 for the curved part of the cylindrical gaussian surface—there is no flux through this part of the gaussian surface because \mathbf{E} is parallel to the surface. There is no flux through the flat face of the cylinder inside the conductor because here $\mathbf{E} = 0$; this satisfies condition (4). Hence, the net flux through the gaussian surface is that through only the flat face outside the conductor, where the field is perpendicular to the gaussian surface. Using conditions (1) and (2) for this face, the flux is EA , where E is the electric field just outside the conductor and A is the area of the cylinder's face. Applying Gauss's law to this surface, we obtain

$$\Phi_E = \oint E dA = EA = \frac{q_{\text{in}}}{\epsilon_0} = \frac{\sigma A}{\epsilon_0}$$

where we have used the fact that $q_{\text{in}} = \sigma A$. Solving for E gives for the electric field just outside a charged conductor

$$E = \frac{\sigma}{\epsilon_0} \quad (24.9)$$

Figure 24.19 shows electric field lines made visible by pieces of thread floating in oil. Notice that the field lines are perpendicular to both the cylindrical conducting surface and the straight conducting surface.

Quick Quiz 24.6 Your little brother likes to rub his feet on the carpet and then touch you to give you a shock. While you are trying to escape the shock treatment, you discover a hollow metal cylinder in your basement, large enough to climb inside. In which of the following cases will you *not* be shocked? (a) You climb inside the cylinder, making contact with the inner surface, and your charged brother touches the outer metal surface. (b) Your charged brother is inside touching the inner metal surface and you are outside, touching the outer metal surface. (c) Both of you are outside the cylinder, touching its outer metal surface but not touching each other directly.

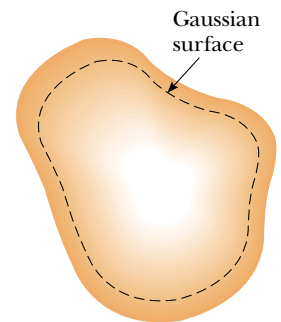

Figure 24.17 A conductor of arbitrary shape. The broken line represents a gaussian surface that can be as close to the surface of the conductor as we wish.

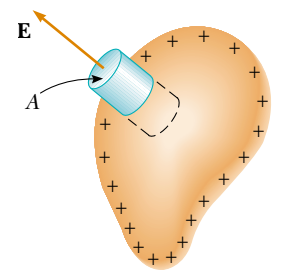

Figure 24.18 A gaussian surface in the shape of a small cylinder is used to calculate the electric field just outside a charged conductor. The flux through the gaussian surface is EA . Remember that \mathbf{E} is zero inside the conductor.

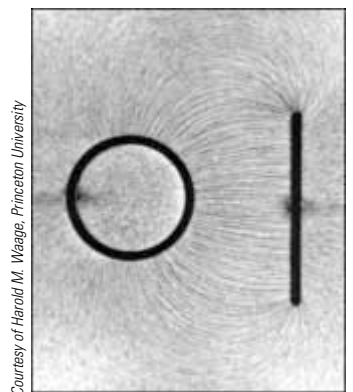

Figure 24.19 Electric field pattern surrounding a charged conducting plate placed near an oppositely charged conducting cylinder. Small pieces of thread suspended in oil align with the electric field lines. Note that (1) the field lines are perpendicular to both conductors and (2) there are no lines inside the cylinder ($E = 0$).

Example 24.10 A Sphere Inside a Spherical Shell**Interactive**

A solid conducting sphere of radius a carries a net positive charge $2Q$. A conducting spherical shell of inner radius b and outer radius c is concentric with the solid sphere and carries a net charge $-Q$. Using Gauss's law, find the electric field in the regions labeled ①, ②, ③, and ④ in Figure 24.20 and the charge distribution on the shell when the entire system is in electrostatic equilibrium.

Solution First note that the charge distributions on both the sphere and the shell are characterized by spherical symmetry around their common center. To determine the electric field at various distances r from this center, we construct a spherical gaussian surface for each of the four regions of interest. Such a surface for region ② is shown in Figure 24.20.

To find E inside the solid sphere (region ①), consider a gaussian surface of radius $r < a$. Because there can be no charge inside a conductor in electrostatic equilibrium, we see that $q_{\text{in}} = 0$; thus, on the basis of Gauss's law and symmetry, $E_1 = 0$ for $r < a$.

In region ②—between the surface of the solid sphere and the inner surface of the shell—we construct a spherical gaussian surface of radius r where $a < r < b$ and note that the charge inside this surface is $+2Q$ (the charge on the solid sphere). Because of the spherical symmetry, the electric field lines must be directed radially outward and be

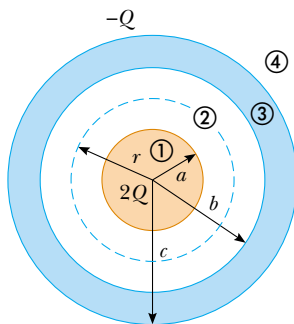

Figure 24.20 (Example 24.10) A solid conducting sphere of radius a and carrying a charge $2Q$ surrounded by a conducting spherical shell carrying a charge $-Q$.

constant in magnitude on the gaussian surface. Following Example 24.4 and using Gauss's law, we find that

$$E_2 A = E_2 (4\pi r^2) = \frac{q_{\text{in}}}{\epsilon_0} = \frac{2Q}{\epsilon_0}$$

$$E_2 = \frac{2Q}{4\pi\epsilon_0 r^2} = \frac{2k_e Q}{r^2} \quad (\text{for } a < r < b)$$

In region ④, where $r > c$, the spherical gaussian surface we construct surrounds a total charge of $q_{\text{in}} = 2Q + (-Q) = Q$. Therefore, application of Gauss's law to this surface gives

$$E_4 = \frac{k_e Q}{r^2} \quad (\text{for } r > c)$$

In region ③, the electric field must be zero because the spherical shell is also a conductor in equilibrium. Figure 24.21 shows a graphical representation of the variation of electric field with r .

If we construct a gaussian surface of radius r where $b < r < c$, we see that q_{in} must be zero because $E_3 = 0$. From this argument, we conclude that the charge on the inner surface of the spherical shell must be $-2Q$ to cancel the charge $+2Q$ on the solid sphere. Because the net charge on the shell is $-Q$, we conclude that its outer surface must carry a charge $+Q$.

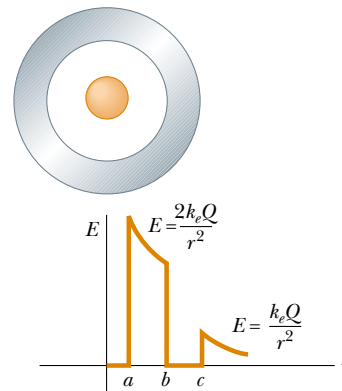

Figure 24.21 (Example 24.10) A plot of E versus r for the two-conductor system shown in Figure 24.20.



Explore the electric field of the system in Figure 24.20 at the Interactive Worked Example link at <http://www.pse6.com>.

24.5 Formal Derivation of Gauss's Law

One way of deriving Gauss's law involves *solid angles*. Consider a spherical surface of radius r containing an area element ΔA . The solid angle $\Delta\Omega$ (Ω : uppercase Greek omega) subtended at the center of the sphere by this element is defined to be

$$\Delta\Omega \equiv \frac{\Delta A}{r^2}$$

From this equation, we see that $\Delta\Omega$ has no dimensions because ΔA and r^2 both have dimensions L^2 . The dimensionless unit of a solid angle is the **steradian**. (You may want to compare this equation to Equation 10.1b, the definition of the radian.) Because the

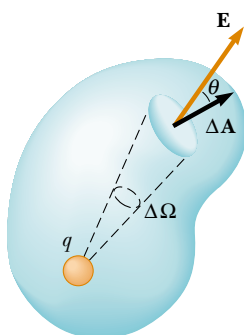

Figure 24.22 A closed surface of arbitrary shape surrounds a point charge q . The net electric flux through the surface is independent of the shape of the surface.

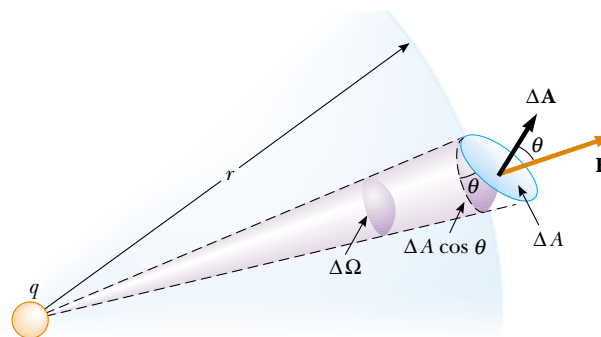

Figure 24.23 The area element ΔA subtends a solid angle $\Delta\Omega = (\Delta A \cos \theta)/r^2$ at the charge q .

surface area of a sphere is $4\pi r^2$, the total solid angle subtended by the sphere is

$$\Omega = \frac{4\pi r^2}{r^2} = 4\pi \text{ steradians}$$

Now consider a point charge q surrounded by a closed surface of arbitrary shape (Fig. 24.22). The total electric flux through this surface can be obtained by evaluating $\mathbf{E} \cdot \Delta\mathbf{A}$ for each small area element ΔA and summing over all elements. The flux through each element is

$$\Delta\Phi_E = \mathbf{E} \cdot \Delta\mathbf{A} = (E \cos \theta)\Delta A = k_e q \frac{\Delta A \cos \theta}{r^2}$$

where r is the distance from the charge to the area element, θ is the angle between the electric field \mathbf{E} and $\Delta\mathbf{A}$ for the element, and $E = k_e q/r^2$ for a point charge. In Figure 24.23, we see that the projection of the area element perpendicular to the radius vector is $\Delta A \cos \theta$. Thus, the quantity $(\Delta A \cos \theta)/r^2$ is equal to the solid angle $\Delta\Omega$ that the surface element ΔA subtends at the charge q . We also see that $\Delta\Omega$ is equal to the solid angle subtended by the area element of a spherical surface of radius r . Because the total solid angle at a point is 4π steradians, the total flux through the closed surface is

$$\Phi_E = k_e q \oint \frac{dA \cos \theta}{r^2} = k_e q \oint d\Omega = 4\pi k_e q = \frac{q}{\epsilon_0}$$

Thus we have derived Gauss's law, Equation 24.6. Note that this result is independent of the shape of the closed surface and independent of the position of the charge within the surface.

SUMMARY

Electric flux is proportional to the number of electric field lines that penetrate a surface. If the electric field is uniform and makes an angle θ with the normal to a surface of area A , the electric flux through the surface is

$$\Phi_E = EA \cos \theta \quad (24.2)$$

In general, the electric flux through a surface is

$$\Phi_E = \int_{\text{surface}} \mathbf{E} \cdot d\mathbf{A} \quad (24.3)$$



Take a practice test for this chapter by clicking on the Practice Test link at <http://www.pse6.com>.

Table 24.1

Typical Electric Field Calculations Using Gauss's Law		
Charge Distribution	Electric Field	Location
Insulating sphere of radius R , uniform charge density, and total charge Q	$k_e \frac{Q}{r^2}$	$r > R$
	$k_e \frac{Q}{R^2} r$	$r < R$
Thin spherical shell of radius R and total charge Q	$k_e \frac{Q}{r^2}$	$r > R$
	0	$r < R$
Line charge of infinite length and charge per unit length λ	$2k_e \frac{\lambda}{r}$	Outside the line
Infinite charged plane having surface charge density σ	$\frac{\sigma}{2\epsilon_0}$	Everywhere outside the plane
Conductor having surface charge density σ	$\frac{\sigma}{\epsilon_0}$	Just outside the conductor
	0	Inside the conductor

You should be able to apply Equations 24.2 and 24.3 in a variety of situations, particularly those in which symmetry simplifies the calculation.

Gauss's law says that the net electric flux Φ_E through any closed gaussian surface is equal to the *net* charge q_{in} inside the surface divided by ϵ_0 :

$$\Phi_E = \oint \mathbf{E} \cdot d\mathbf{A} = \frac{q_{\text{in}}}{\epsilon_0} \quad (24.6)$$

Using Gauss's law, you can calculate the electric field due to various symmetric charge distributions. Table 24.1 lists some typical results.

A conductor in **electrostatic equilibrium** has the following properties:

1. The electric field is zero everywhere inside the conductor.
2. Any net charge on the conductor resides entirely on its surface.
3. The electric field just outside the conductor is perpendicular to its surface and has a magnitude σ/ϵ_0 , where σ is the surface charge density at that point.
4. On an irregularly shaped conductor, the surface charge density is greatest where the radius of curvature of the surface is the smallest.

QUESTIONS

1. The Sun is lower in the sky during the winter months than it is in the summer. How does this change the flux of sunlight hitting a given area on the surface of the Earth? How does this affect the weather?
2. If the electric field in a region of space is zero, can you conclude that no electric charges are in that region? Explain.
3. If more electric field lines leave a gaussian surface than enter it, what can you conclude about the net charge enclosed by that surface?
4. A uniform electric field exists in a region of space in which there are no charges. What can you conclude about the net electric flux through a gaussian surface placed in this region of space?
5. If the total charge inside a closed surface is known but the distribution of the charge is unspecified, can you use Gauss's law to find the electric field? Explain.
6. Explain why the electric flux through a closed surface with a given enclosed charge is independent of the size or shape of the surface.
7. Consider the electric field due to a nonconducting infinite plane having a uniform charge density. Explain why the electric field does not depend on the distance from the plane, in terms of the spacing of the electric field lines.
8. Use Gauss's law to explain why electric field lines must begin or end on electric charges. (*Suggestion:* Change the size of the gaussian surface.)

9. On the basis of the repulsive nature of the force between like charges and the freedom of motion of charge within a conductor, explain why excess charge on an isolated conductor must reside on its surface.
10. A person is placed in a large hollow metallic sphere that is insulated from ground. If a large charge is placed on the sphere, will the person be harmed upon touching the inside of the sphere? Explain what will happen if the person also has an initial charge whose sign is opposite that of the charge on the sphere.
11. Two solid spheres, both of radius R , carry identical total charges, Q . One sphere is a good conductor while the other is an insulator. If the charge on the insulating sphere is uniformly distributed throughout its interior volume, how do the electric fields outside these two spheres compare? Are the fields identical inside the two spheres?
12. A common demonstration involves charging a rubber balloon, which is an insulator, by rubbing it on your hair, and touching the balloon to a ceiling or wall, which is also an insulator. The electrical attraction between the charged balloon and the neutral wall results in the balloon sticking to the wall. Imagine now that we have two infinitely large flat sheets of insulating material. One is charged and the other is neutral. If these are brought into contact, will an attractive force exist between them, as there was for the balloon and the wall?
13. You may have heard that one of the safer places to be during a lightning storm is inside a car. Why would this be the case?

PROBLEMS

1, 2, 3 = straightforward, intermediate, challenging □ = full solution available in the *Student Solutions Manual and Study Guide*



= coached solution with hints available at <http://www.pse6.com> = computer useful in solving problem

= paired numerical and symbolic problems

Section 24.1 Electric Flux

- An electric field with a magnitude of 3.50 kN/C is applied along the x axis. Calculate the electric flux through a rectangular plane 0.350 m wide and 0.700 m long assuming that (a) the plane is parallel to the yz plane; (b) the plane is parallel to the xy plane; (c) the plane contains the y axis, and its normal makes an angle of 40.0° with the x axis.
- A vertical electric field of magnitude $2.00 \times 10^4 \text{ N/C}$ exists above the Earth's surface on a day when a thunderstorm is brewing. A car with a rectangular size of 6.00 m by 3.00 m is traveling along a roadway sloping downward at 10.0° . Determine the electric flux through the bottom of the car.
- A 40.0-cm -diameter loop is rotated in a uniform electric field until the position of maximum electric flux is found. The flux in this position is measured to be $5.20 \times 10^5 \text{ N}\cdot\text{m}^2/\text{C}$. What is the magnitude of the electric field?
- Consider a closed triangular box resting within a horizontal electric field of magnitude $E = 7.80 \times 10^4 \text{ N/C}$ as shown in Figure P24.4. Calculate the electric flux through (a) the vertical rectangular surface, (b) the slanted surface, and (c) the entire surface of the box.

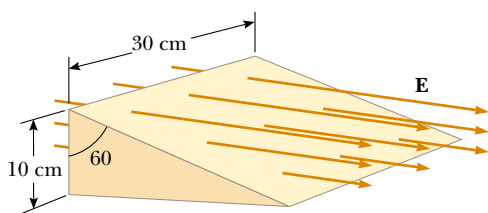

Figure P24.4

- A uniform electric field $a\hat{i} + b\hat{j}$ intersects a surface of area A . What is the flux through this area if the surface lies (a) in the yz plane? (b) in the xz plane? (c) in the xy plane?

- A point charge q is located at the center of a uniform ring having linear charge density λ and radius a , as shown in Figure P24.6. Determine the total electric flux through a sphere centered at the point charge and having radius R , where $R < a$.

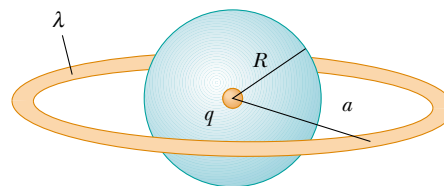

Figure P24.6

- A pyramid with horizontal square base, 6.00 m on each side, and a height of 4.00 m is placed in a vertical electric field of 52.0 N/C . Calculate the total electric flux through the pyramid's four slanted surfaces.
- A cone with base radius R and height h is located on a horizontal table. A horizontal uniform field E penetrates the cone, as shown in Figure P24.8. Determine the electric flux that enters the left-hand side of the cone.

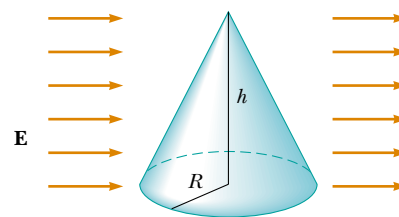

Figure P24.8

Section 24.2 Gauss's Law

- The following charges are located inside a submarine: $5.00 \mu\text{C}$, $-9.00 \mu\text{C}$, $27.0 \mu\text{C}$, and $-84.0 \mu\text{C}$. (a) Calculate

the net electric flux through the hull of the submarine.
 (b) Is the number of electric field lines leaving the submarine greater than, equal to, or less than the number entering it?

10. The electric field everywhere on the surface of a thin spherical shell of radius 0.750 m is measured to be 890 N/C and points radially toward the center of the sphere. (a) What is the net charge within the sphere's surface? (b) What can you conclude about the nature and distribution of the charge inside the spherical shell?
11. Four closed surfaces, S_1 through S_4 , together with the charges $-2Q$, Q , and $-Q$ are sketched in Figure P24.11. (The colored lines are the intersections of the surfaces with the page.) Find the electric flux through each surface.

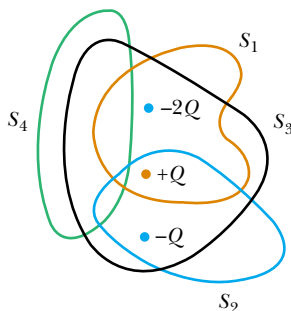

Figure P24.11

12. (a) A point charge q is located a distance d from an infinite plane. Determine the electric flux through the plane due to the point charge. (b) **What If?** A point charge q is located a *very small* distance from the center of a *very large* square on the line perpendicular to the square and going through its center. Determine the approximate electric flux through the square due to the point charge. (c) Explain why the answers to parts (a) and (b) are identical.
13. Calculate the total electric flux through the paraboloidal surface due to a uniform electric field of magnitude E_0 in the direction shown in Figure P24.13.

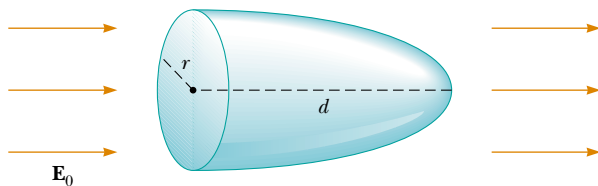

Figure P24.13

14. A point charge of $12.0 \mu\text{C}$ is placed at the center of a spherical shell of radius 22.0 cm. What is the total electric flux through (a) the surface of the shell and (b) any hemispherical surface of the shell? (c) Do the results depend on the radius? Explain.

15. A point charge Q is located just above the center of the flat face of a hemisphere of radius R as shown in Figure P24.15. What is the electric flux (a) through the curved surface and (b) through the flat face?

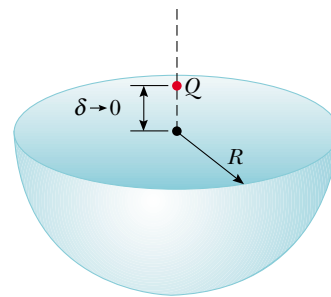

Figure P24.15

16. In the air over a particular region at an altitude of 500 m above the ground the electric field is 120 N/C directed downward. At 600 m above the ground the electric field is 100 N/C downward. What is the average volume charge density in the layer of air between these two elevations? Is it positive or negative?

17. A point charge $Q = 5.00 \mu\text{C}$ is located at the center of a cube of edge $L = 0.100$ m. In addition, six other identical point charges having $q = -1.00 \mu\text{C}$ are positioned symmetrically around Q as shown in Figure P24.17. Determine the electric flux through one face of the cube.

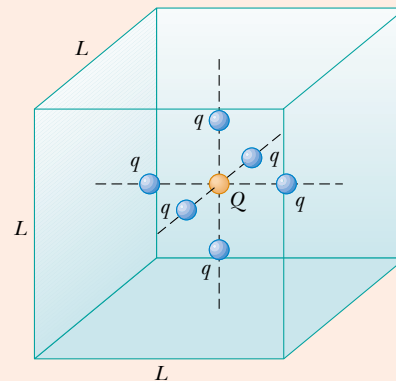

Figure P24.17 Problems 17 and 18.

18. A positive point charge Q is located at the center of a cube of edge L . In addition, six other identical negative point charges q are positioned symmetrically around Q as shown in Figure P24.17. Determine the electric flux through one face of the cube.

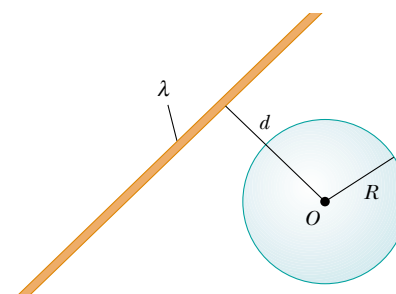

Figure P24.19

19. An infinitely long line charge having a uniform charge per unit length λ lies a distance d from point O as shown in Figure P24.19. Determine the total electric flux through the surface of a sphere of radius R centered at O resulting from this line charge. Consider both cases, where $R < d$ and $R > d$.
20. An uncharged nonconducting hollow sphere of radius 10.0 cm surrounds a $10.0\text{-}\mu\text{C}$ charge located at the origin of a cartesian coordinate system. A drill with a radius of 1.00 mm is aligned along the z axis, and a hole is drilled in the sphere. Calculate the electric flux through the hole.
21. A charge of $170\ \mu\text{C}$ is at the center of a cube of edge 80.0 cm. (a) Find the total flux through each face of the cube. (b) Find the flux through the whole surface of the cube. (c) **What If?** Would your answers to parts (a) or (b) change if the charge were not at the center? Explain.
22. The line ag in Figure P24.22 is a diagonal of a cube. A point charge q is located on the extension of line ag , very close to vertex a of the cube. Determine the electric flux through each of the sides of the cube which meet at the point a .

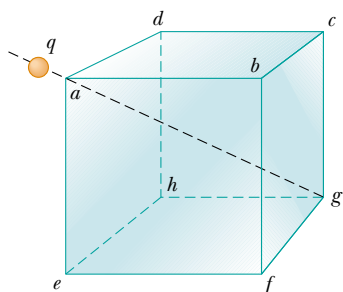

Figure P24.22

Section 24.3 Application of Gauss's Law to Various Charge Distributions

23. Determine the magnitude of the electric field at the surface of a lead-208 nucleus, which contains 82 protons and 126 neutrons. Assume the lead nucleus has a volume 208 times that of one proton, and consider a proton to be a sphere of radius 1.20×10^{-15} m.
24. A solid sphere of radius 40.0 cm has a total positive charge of $26.0\ \mu\text{C}$ uniformly distributed throughout its volume. Calculate the magnitude of the electric field (a) 0 cm, (b) 10.0 cm, (c) 40.0 cm, and (d) 60.0 cm from the center of the sphere.
25. A 10.0-g piece of Styrofoam carries a net charge of $-0.700\ \mu\text{C}$ and floats above the center of a large horizontal sheet of plastic that has a uniform charge density on its surface. What is the charge per unit area on the plastic sheet?
26. A cylindrical shell of radius 7.00 cm and length 240 cm has its charge uniformly distributed on its curved surface. The magnitude of the electric field at a point 19.0 cm radially outward from its axis (measured from the midpoint of the shell) is $36.0\ \text{kN/C}$. Find (a) the net charge on the shell and (b) the electric field at a point 4.00 cm from the axis, measured radially outward from the midpoint of the shell.
27. A particle with a charge of $-60.0\ \text{nC}$ is placed at the center of a nonconducting spherical shell of inner radius 20.0 cm and outer radius 25.0 cm. The spherical shell carries charge with a uniform density of $-1.33\ \mu\text{C}/\text{m}^3$. A proton moves in a circular orbit just outside the spherical shell. Calculate the speed of the proton.
28. A nonconducting wall carries a uniform charge density of $8.60\ \mu\text{C}/\text{cm}^2$. What is the electric field 7.00 cm in front of the wall? Does your result change as the distance from the wall is varied?
29. Consider a long cylindrical charge distribution of radius R with a uniform charge density ρ . Find the electric field at distance r from the axis where $r < R$.
30. A solid plastic sphere of radius 10.0 cm has charge with uniform density throughout its volume. The electric field 5.00 cm from the center is $86.0\ \text{kN/C}$ radially inward. Find the magnitude of the electric field 15.0 cm from the center.
31. Consider a thin spherical shell of radius 14.0 cm with a total charge of $32.0\ \mu\text{C}$ distributed uniformly on its surface. Find the electric field (a) 10.0 cm and (b) 20.0 cm from the center of the charge distribution.
32. In nuclear fission, a nucleus of uranium-238, which contains 92 protons, can divide into two smaller spheres, each having 46 protons and a radius of 5.90×10^{-15} m. What is the magnitude of the repulsive electric force pushing the two spheres apart?
33. Fill two rubber balloons with air. Suspend both of them from the same point and let them hang down on strings of equal length. Rub each with wool or on your hair, so that they hang apart with a noticeable separation from each other. Make order-of-magnitude estimates of (a) the force on each, (b) the charge on each, (c) the field each creates at the center of the other, and (d) the total flux of electric field created by each balloon. In your solution state the quantities you take as data and the values you measure or estimate for them.
34. An insulating solid sphere of radius a has a uniform volume charge density and carries a total positive charge Q . A spherical gaussian surface of radius r , which shares a common center with the insulating sphere, is inflated starting from $r = 0$. (a) Find an expression for the electric flux passing through the surface of the gaussian sphere as a function of r for $r < a$. (b) Find an expression for the electric flux for $r > a$. (c) Plot the flux versus r .
35. A uniformly charged, straight filament 7.00 m in length has a total positive charge of $2.00\ \mu\text{C}$. An uncharged cardboard cylinder 2.00 cm in length and 10.0 cm in radius surrounds the filament at its center, with the filament as the axis of the cylinder. Using reasonable approximations, find (a) the electric field at the surface of the cylinder and (b) the total electric flux through the cylinder.
36. An insulating sphere is 8.00 cm in diameter and carries a $5.70\text{-}\mu\text{C}$ charge uniformly distributed throughout its interior volume. Calculate the charge enclosed by a concentric spherical surface with radius (a) $r = 2.00$ cm and (b) $r = 6.00$ cm.
37. A large flat horizontal sheet of charge has a charge per unit area of $9.00\ \mu\text{C}/\text{m}^2$. Find the electric field just above the middle of the sheet.

38. The charge per unit length on a long, straight filament is $-90.0 \mu\text{C}/\text{m}$. Find the electric field (a) 10.0 cm, (b) 20.0 cm, and (c) 100 cm from the filament, where distances are measured perpendicular to the length of the filament.

Section 24.4 Conductors in Electrostatic Equilibrium

39. A long, straight metal rod has a radius of 5.00 cm and a charge per unit length of $30.0 \text{ nC}/\text{m}$. Find the electric field (a) 3.00 cm, (b) 10.0 cm, and (c) 100 cm from the axis of the rod, where distances are measured perpendicular to the rod.
40. On a clear, sunny day, a vertical electric field of about $130 \text{ N}/\text{C}$ points down over flat ground. What is the surface charge density on the ground for these conditions?
41. A very large, thin, flat plate of aluminum of area A has a total charge Q uniformly distributed over its surfaces. Assuming the same charge is spread uniformly over the upper surface of an otherwise identical glass plate, compare the electric fields just above the center of the upper surface of each plate.
42. A solid copper sphere of radius 15.0 cm carries a charge of 40.0 nC . Find the electric field (a) 12.0 cm, (b) 17.0 cm, and (c) 75.0 cm from the center of the sphere. (d) **What If?** How would your answers change if the sphere were hollow?
43. A square plate of copper with 50.0-cm sides has no net charge and is placed in a region of uniform electric field of $80.0 \text{ kN}/\text{C}$ directed perpendicularly to the plate. Find (a) the charge density of each face of the plate and (b) the total charge on each face.
44. A solid conducting sphere of radius 2.00 cm has a charge of $8.00 \mu\text{C}$. A conducting spherical shell of inner radius 4.00 cm and outer radius 5.00 cm is concentric with the solid sphere and has a total charge of $-4.00 \mu\text{C}$. Find the electric field at (a) $r = 1.00 \text{ cm}$, (b) $r = 3.00 \text{ cm}$, (c) $r = 4.50 \text{ cm}$, and (d) $r = 7.00 \text{ cm}$ from the center of this configuration.
45. Two identical conducting spheres each having a radius of 0.500 cm are connected by a light 2.00-m-long conducting wire. A charge of $60.0 \mu\text{C}$ is placed on one of the conductors. Assume that the surface distribution of charge on each sphere is uniform. Determine the tension in the wire.
46. The electric field on the surface of an irregularly shaped conductor varies from $56.0 \text{ kN}/\text{C}$ to $28.0 \text{ kN}/\text{C}$. Calculate the local surface charge density at the point on the surface where the radius of curvature of the surface is (a) greatest and (b) smallest.

47. A long, straight wire is surrounded by a hollow metal cylinder whose axis coincides with that of the wire. The wire has a charge per unit length of λ , and the cylinder has a net charge per unit length of 2λ . From this information, use Gauss's law to find (a) the charge per unit length on the inner and outer surfaces of the cylinder and (b) the electric field outside the cylinder, a distance r from the axis.

48. A conducting spherical shell of radius 15.0 cm carries a net charge of $-6.40 \mu\text{C}$ uniformly distributed on its surface. Find the electric field at points (a) just outside the shell and (b) inside the shell.

49.  A thin square conducting plate 50.0 cm on a side lies in the xy plane. A total charge of $4.00 \times 10^{-8} \text{ C}$ is placed on the plate. Find (a) the charge density on the plate, (b) the electric field just above the plate, and (c) the electric field just below the plate. You may assume that the charge density is uniform.

50. A conducting spherical shell of inner radius a and outer radius b carries a net charge Q . A point charge q is placed at the center of this shell. Determine the surface charge density on (a) the inner surface of the shell and (b) the outer surface of the shell.
51. A hollow conducting sphere is surrounded by a larger concentric spherical conducting shell. The inner sphere has charge $-Q$, and the outer shell has net charge $+3Q$. The charges are in electrostatic equilibrium. Using Gauss's law, find the charges and the electric fields everywhere.
52. A positive point charge is at a distance $R/2$ from the center of an uncharged thin conducting spherical shell of radius R . Sketch the electric field lines set up by this arrangement both inside and outside the shell.

Section 24.5 Formal Derivation of Gauss's Law

53. A sphere of radius R surrounds a point charge Q , located at its center. (a) Show that the electric flux through a circular cap of half-angle θ (Fig. P24.53) is

$$\Phi_E = \frac{Q}{2\epsilon_0} (1 - \cos \theta)$$

What is the flux for (b) $\theta = 90^\circ$ and (c) $\theta = 180^\circ$?

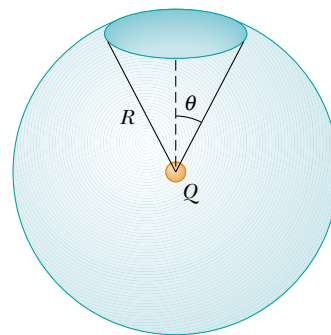

Figure P24.53

Additional Problems

54. A nonuniform electric field is given by the expression $\mathbf{E} = ay\mathbf{i} + bz\mathbf{j} + cx\mathbf{k}$, where a , b , and c are constants. Determine the electric flux through a rectangular surface in the xy plane, extending from $x = 0$ to $x = w$ and from $y = 0$ to $y = h$.

55. A solid insulating sphere of radius a carries a net positive charge $3Q$, uniformly distributed throughout its volume. Concentric with this sphere is a conducting spherical shell with inner radius b and outer radius c , and having a net charge $-Q$, as shown in Figure P24.55. (a) Construct a spherical gaussian surface of radius $r > c$ and find the net charge enclosed by this surface. (b) What is the direction of the electric field at $r > c$? (c) Find the electric field at $r > c$. (d) Find the electric field in the region with radius r where $c > r > b$. (e) Construct a spherical gaussian surface of radius r , where $c > r > b$, and find the net charge enclosed by this surface. (f) Construct a spherical gaussian surface of radius r , where $b > r > a$, and find the net charge enclosed by this surface. (g) Find the electric field in the region $b > r > a$. (h) Construct a spherical gaussian surface of radius $r < a$, and find an expression for the net charge enclosed by this surface, as a function of r . Note that the charge inside this surface is less than $3Q$. (i) Find the electric field in the region $r < a$. (j) Determine the charge on the inner surface of the conducting shell. (k) Determine the charge on the outer surface of the conducting shell. (l) Make a plot of the magnitude of the electric field versus r .

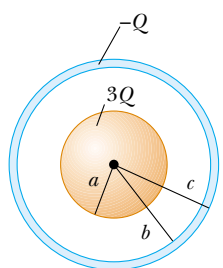

Figure P24.55

56. Consider two identical conducting spheres whose surfaces are separated by a small distance. One sphere is given a large net positive charge while the other is given a small net positive charge. It is found that the force between them is attractive even though both spheres have net charges of the same sign. Explain how this is possible.

57. A solid, insulating sphere of radius a has a uniform charge density ρ and a total charge Q . Concentric with this sphere is an uncharged, conducting hollow sphere whose inner and outer radii are b and c , as shown in Figure P24.57. (a) Find the magnitude of the electric field in the regions $r < a$, $a < r < b$, $b < r < c$, and $r > c$. (b) Determine the induced charge per unit area on the inner and outer surfaces of the hollow sphere.

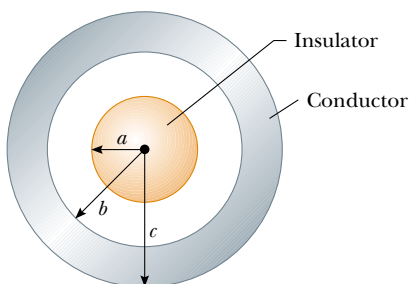

Figure P24.57 Problems 57 and 58.

58. For the configuration shown in Figure P24.57, suppose that $a = 5.00$ cm, $b = 20.0$ cm, and $c = 25.0$ cm. Furthermore, suppose that the electric field at a point 10.0 cm from the center is measured to be 3.60×10^3 N/C radially inward while the electric field at a point 50.0 cm from the center is 2.00×10^2 N/C radially outward. From this information, find (a) the charge on the insulating sphere, (b) the net charge on the hollow conducting sphere, and (c) the charges on the inner and outer surfaces of the hollow conducting sphere.

59. A particle of mass m and charge q moves at high speed along the x axis. It is initially near $x = -\infty$, and it ends up near $x = +\infty$. A second charge Q is fixed at the point $x = 0$, $y = -d$. As the moving charge passes the stationary charge, its x component of velocity does not change appreciably, but it acquires a small velocity in the y direction. Determine the angle through which the moving charge is deflected. *Suggestion:* The integral you encounter in determining v_y can be evaluated by applying Gauss's law to a long cylinder of radius d , centered on the stationary charge.

60. **Review problem.** An early (incorrect) model of the hydrogen atom, suggested by J. J. Thomson, proposed that a positive cloud of charge $+e$ was uniformly distributed throughout the volume of a sphere of radius R , with the electron an equal-magnitude negative point charge $-e$ at the center. (a) Using Gauss's law, show that the electron would be in equilibrium at the center and, if displaced from the center a distance $r < R$, would experience a restoring force of the form $F = -Kr$, where K is a constant. (b) Show that $K = k_e e^2 / R^3$. (c) Find an expression for the frequency f of simple harmonic oscillations that an electron of mass m_e would undergo if displaced a small distance ($< R$) from the center and released. (d) Calculate a numerical value for R that would result in a frequency of 2.47×10^{15} Hz, the frequency of the light radiated in the most intense line in the hydrogen spectrum.

61. An infinitely long cylindrical insulating shell of inner radius a and outer radius b has a uniform volume charge density ρ . A line of uniform linear charge density λ is placed along the axis of the shell. Determine the electric field everywhere.

62. Two infinite, nonconducting sheets of charge are parallel to each other, as shown in Figure P24.62. The sheet on the left has a uniform surface charge density σ , and the one

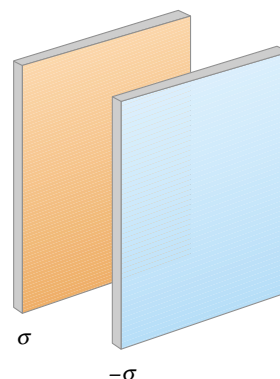

Figure P24.62

on the right has a uniform charge density $-\sigma$. Calculate the electric field at points (a) to the left of, (b) in between, and (c) to the right of the two sheets.

63. What If? Repeat the calculations for Problem 62 when both sheets have *positive* uniform surface charge densities of value σ .

64. A sphere of radius $2a$ is made of a nonconducting material that has a uniform volume charge density ρ . (Assume that the material does not affect the electric field.) A spherical cavity of radius a is now removed from the sphere, as shown in Figure P24.64. Show that the electric field within the cavity is uniform and is given by $E_x = 0$ and $E_y = \rho a/3\epsilon_0$. (*Suggestion:* The field within the cavity is the superposition of the field due to the original uncut sphere, plus the field due to a sphere the size of the cavity with a uniform negative charge density $-\rho$.)

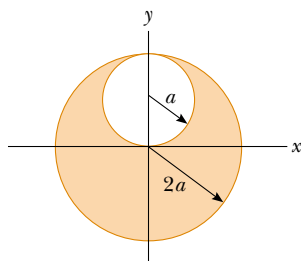

Figure P24.64

65. A uniformly charged spherical shell with surface charge density σ contains a circular hole in its surface. The radius of the hole is small compared with the radius of the sphere. What is the electric field at the center of the hole? (*Suggestion:* This problem, like Problem 64, can be solved by using the idea of superposition.)

66. A closed surface with dimensions $a = b = 0.400$ m and $c = 0.600$ m is located as in Figure P24.66. The left edge of the closed surface is located at position $x = a$. The electric field throughout the region is nonuniform and given by $\mathbf{E} = (3.0 + 2.0x^2)\hat{\mathbf{i}}$ N/C, where x is in meters. Calculate the net electric flux leaving the closed surface. What net charge is enclosed by the surface?

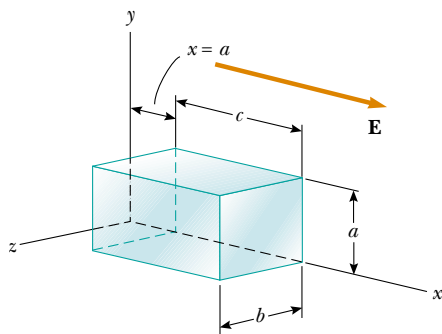

Figure P24.66

67. A solid insulating sphere of radius R has a nonuniform charge density that varies with r according to the expression $\rho = Ar^2$, where A is a constant and $r < R$ is measured from the center of the sphere. (a) Show that the magnitude of the electric field outside ($r > R$) the sphere is $E = AR^5/5\epsilon_0r^2$. (b) Show that the magnitude of the electric field inside ($r < R$) the sphere is $E = Ar^3/5\epsilon_0$. (*Suggestion:* The total charge Q on the sphere is equal to the integral of ρdV , where r extends from 0 to R ; also, the charge q within a radius $r < R$ is less than Q . To evaluate the integrals, note that the volume element dV for a spherical shell of radius r and thickness dr is equal to $4\pi r^2 dr$.)

68. A point charge Q is located on the axis of a disk of radius R at a distance b from the plane of the disk (Fig. P24.68). Show that if one fourth of the electric flux from the charge passes through the disk, then $R = \sqrt{3}b$.

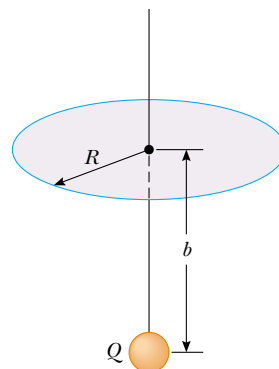

Figure P24.68

69. A spherically symmetric charge distribution has a charge density given by $\rho = a/r$, where a is constant. Find the electric field as a function of r . (*Suggestion:* The charge within a sphere of radius R is equal to the integral of ρdV , where r extends from 0 to R . To evaluate the integral, note that the volume element dV for a spherical shell of radius r and thickness dr is equal to $4\pi r^2 dr$.)

70. An infinitely long insulating cylinder of radius R has a volume charge density that varies with the radius as

$$\rho = \rho_0 \left(a - \frac{r}{b} \right)$$

where ρ_0 , a , and b are positive constants and r is the distance from the axis of the cylinder. Use Gauss's law to determine the magnitude of the electric field at radial distances (a) $r < R$ and (b) $r > R$.

71. Review problem. A slab of insulating material (infinite in two of its three dimensions) has a uniform positive charge density ρ . An edge view of the slab is shown in Figure P24.71. (a) Show that the magnitude of the electric field a distance x from its center and inside the slab is $E = \rho x/\epsilon_0$. (b) **What If?** Suppose an electron of charge $-e$ and mass m_e can move freely within the slab. It is released from rest at a distance x from the center. Show that the electron exhibits simple harmonic motion with a frequency

$$f = \frac{1}{2\pi} \sqrt{\frac{\rho e}{m_e \epsilon_0}}$$

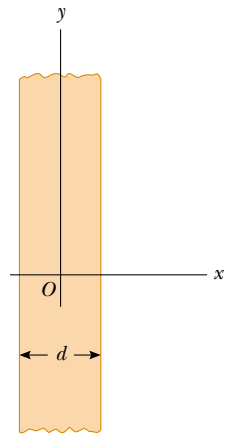

Figure P24.71 Problems 71 and 72.

- 72.** A slab of insulating material has a nonuniform positive charge density $\rho = Cx^2$, where x is measured from the center of the slab as shown in Figure P24.71, and C is a constant. The slab is infinite in the y and z directions. Derive expressions for the electric field in (a) the exterior regions and (b) the interior region of the slab ($-d/2 < x < d/2$).
- 73.** (a) Using the mathematical similarity between Coulomb's law and Newton's law of universal gravitation, show that Gauss's law for gravitation can be written as

$$\oint \mathbf{g} \cdot d\mathbf{A} = -4\pi G m_{\text{in}}$$

where m_{in} is the net mass inside the gaussian surface and $\mathbf{g} = \mathbf{F}_g/m$ represents the gravitational field at any point on

the gaussian surface. (b) Determine the gravitational field at a distance r from the center of the Earth where $r < R_E$, assuming that the Earth's mass density is uniform.

Answers to Quick Quizzes

- 24.1** (e). The same number of field lines pass through a sphere of any size. Because points on the surface of the sphere are closer to the charge, the field is stronger.
- 24.2** (d). All field lines that enter the container also leave the container so that the total flux is zero, regardless of the nature of the field or the container.
- 24.3** (b) and (d). Statement (a) is not necessarily true because an equal number of positive and negative charges could be present inside the surface. Statement (c) is not necessarily true, as can be seen from Figure 24.8: a nonzero electric field exists everywhere on the surface, but the charge is not enclosed within the surface; thus, the net flux is zero.
- 24.4** (c). The charges q_1 and q_4 are outside the surface and contribute zero net flux through S' .
- 24.5** (d). We don't need the surfaces to realize that any given point in space will experience an electric field due to all local source charges.
- 24.6** (a). Charges added to the metal cylinder by your brother will reside on the outer surface of the conducting cylinder. If you are on the inside, these charges cannot transfer to you from the inner surface. For this same reason, you are safe in a metal automobile during a lightning storm.